

RLMEVO

High Performance Plug Fans

Impeller with true airfoil blades

Issue 1.7 EN
January 2013

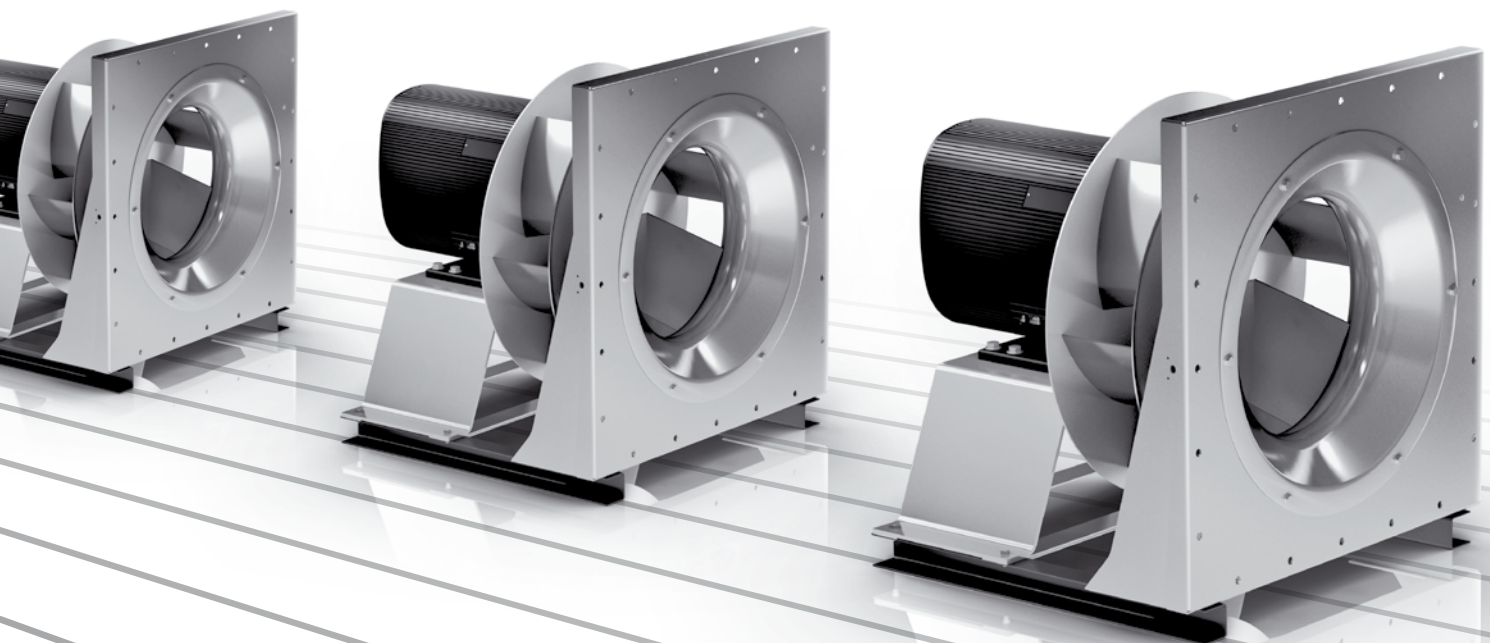

NICOTRA | Gebhardt

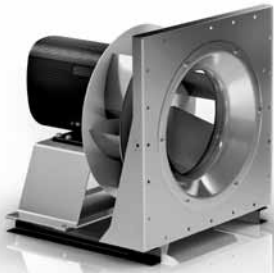

Ready for the next generation

We have accelerated impeller technology with the RLM Evo series, the new generation in our plug fan range. The result: More efficiency and reduced turbulent conditions. And that is highly effective as the Evo series ensures:

- ▶ lower energy consumption
- ▶ lower costs
- ▶ lower noise levels

Nicotra Gebhardt – the professionals in profiling

Nicotra Gebhardt is the first port of call for profiled impeller blades. We brought the first hollow section airfoil blades onto the market in 1975. Since then we have been achieving the absolutely best efficiencies in our fans in every application. Our engineers and technicians use the latest simulation programmes to develop and test new designs. You can rely on the knowledge and experience of specialists.

Don't wait until 2015

Fans must reach ever higher system efficiencies. The EU's ErP directive will prescribe compulsory values in 2013 and will increase them again in 2015.

The new generation of plug fans by Nicotra Gebhardt, already achieved higher efficiency in 2011 than that required as from 2015.

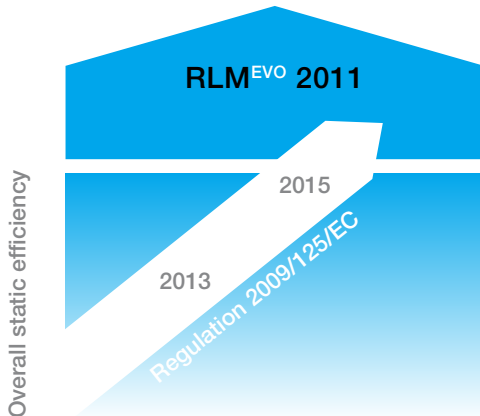

The plus factors of the new Generation

▶ Unparalleled system efficiency for plug fans

The Evo series sets a new standard in efficiency. No other plug fan reaches higher system efficiency.

▶ Innovative blade and impeller shaped for highest efficiencies

The entire shape of the impeller was optimised using a real turbulence profile for the blades. This ensures that the impeller reaches as yet unparalleled high efficiency and takes the top position in aerodynamics.

▶ Optimal pressure and turbulence conditions

The re-designed impeller shape makes optimal pressure and minimised turbulence conditions in the impeller possible. The inclined leading edge of the blade builds pressure more evenly minimising entry and exit losses.

▶ Low operating cost brushless DC motor

The brushless DC motor used by Nicotra Gebhardt is markedly more efficient than conventional drives: It reduces the energy consumption of the fan for partial loads by up to 50 %.

▶ Much quieter

Thanks to their new design the blades and the impeller run with less noise. The entire fan is thus much quieter.

▶ Easy to integrate

Despite their improved performance figures, the Evo series have the same external dimensions and significant operational data as earlier generations of plug fans. They can therefore be easily and quickly exchanged in existing systems or integrated in available machine concepts.

▶ Easy maintenance

Thanks to the construction method and direct drive the Evo series is practically maintenance-free.

The evolutionary elements



► The perfect profile

At the heart of the Evo series are the six blades with rounded inclined leading edges and re-designed hollow profile.

They ensure minimised turbulence conditions in the impeller thus enabling the extraordinary high efficiency of the fan.

Due to their special shape, the blades build up pressure evenly at all sections. The result: Air circulates around the blades better and the turbulence tends to dissipate. This increases not only efficiency but also causes significantly lower noise.



► The innovative high performance impeller

The re-designed high performance impeller makes the Evo series unbeatable in matters of efficiency. To ensure this we optimised the entire shape.

The special shape of the cover disc alone greatly improves turbulence. The width and diameter of the impeller are in an ideal ratio to each other.

The new hollow profile of the blades ensured that the weight of the impeller could be markedly reduced and that, at the same time, a high degree of stability could be reached. Pressure losses on entry were greatly decreased.

And at the exit, where losses had been sustained before, the new impeller shape ensures additional available static pressure.



► The tailored drive

The new generation of our plug fans not only have a perfect impeller but also a precisely matched drive. For this reason, the Evo series, already an innovation in itself, is available with a cutting edge brushless DC motors. Together with such a drive, the Evo series delivers high performance with particularly low energy consumption. Whether during start-up or under base, partial or full load, the efficiency exceeds that of a conventional AC motor in every situation.

Our drives with brushless DCs reach efficiencies of efficiency class IE3 and higher.

Type code

The type code of every fan is composed as follows. Example:

RLM E6-3540-4W-17

■ Index for motor size

■ Motor:

- W = Asynchronous motor (efficiency class IE2)
- D = Asynchronous motor
- BI = Brushless DC motor with integrated control unit (IE3 and higher)
- BE = Brushless DC motor with external control unit (IE3 and higher)

■ N° of poles:

- 2 = 2-poles
- 4 = 4-poles
- 6 = 6-poles

■ Impeller diameter (nominal 400 mm)

■ Connecting diameter (nominal 355 mm)

■ Specification

- 6 = Complete Plug Fan module (motor impeller unit, supporting plate with inlet cone and motor stand on baseframe)

■ Impeller geometry (Series RLM Evo)

■ Drive type

- M = Standard motor

RLM E6-2528

Performance charts

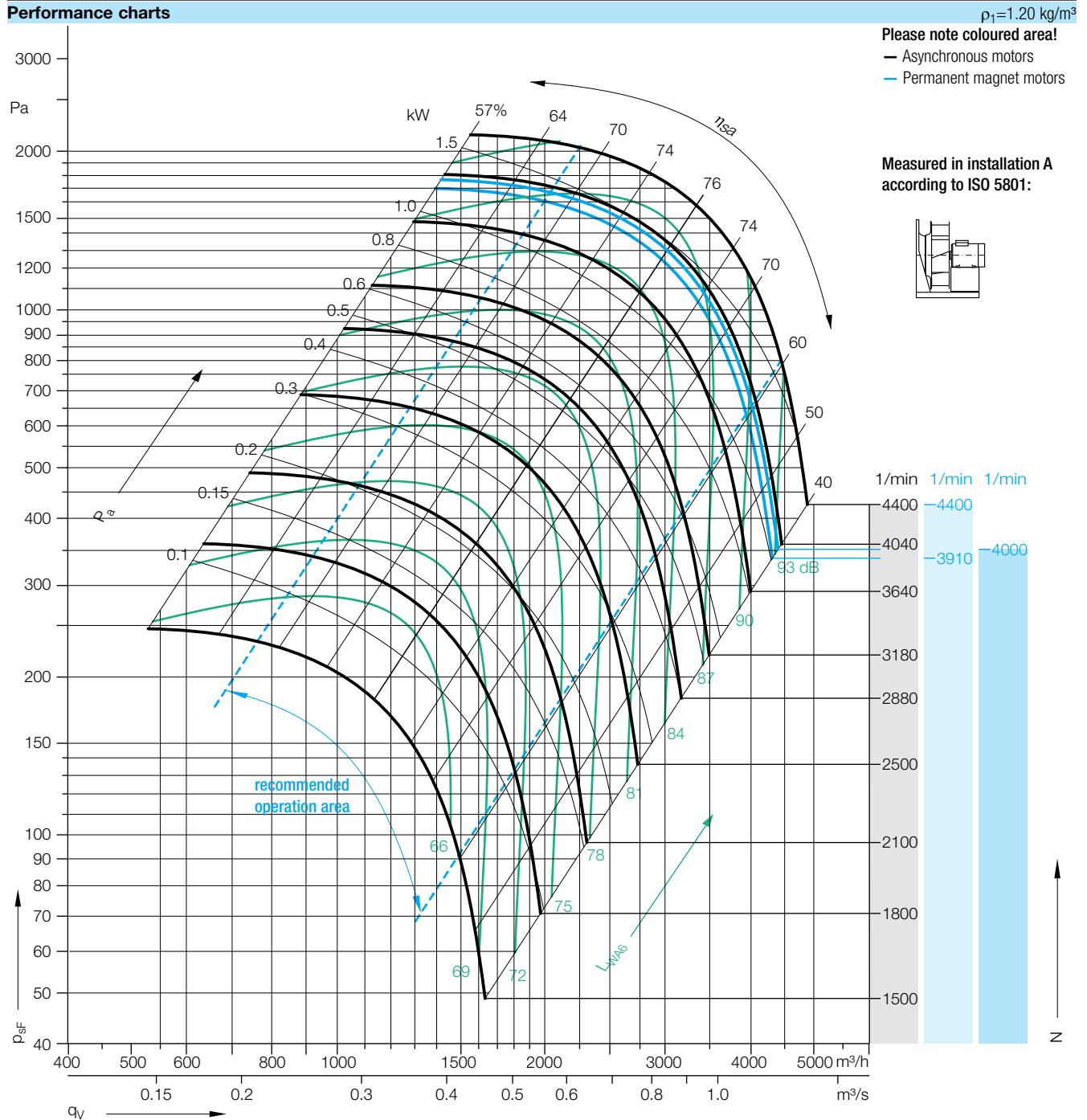

System efficiencies

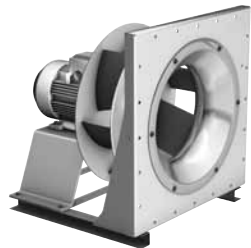

Comparison system efficiencies η_{se} (impeller, motor, inverter)

Model	Speed (1/min)	Motor Type	η_{sa}	64	70	74	76	74	70	60	%
RLM E6-2528-			η_{sa}	64	70	74	76	74	70	60	%
2W-14	4400	Asynchronous	η_{se}	51	56	59	60	59	56	48	%
BI-BW	4400	Permanent magnet	η_{se}	54	59	62	63	61	58	50	%
BE-AV	3910	Permanent magnet	η_{se}	54	59	62	63	61	58	50	%
BE-IG	4000	Permanent magnet	η_{se}	55	61	64	66	64	61	52	%

Formula symbols

- η_{se} = overall static efficiency (impeller, motor, inverter)
- η_{sa} = fan shaft static efficiency
- L_{WA6} = A-weighted sound power level at discharge
- P_a = fan shaft power

RLM E6-2528

EVOLUTION
IS IN THE AIR
RLM^{EVO}

Technical Data

Fan type RLM Evo	Motor power kW (max.)	Mains voltage V	Mains frequency Hz	Nominal speed 1/min	Nominal moment Nm	Nominal current A	max. operating frequency Hz	max. speed 1/min	Motor size **	Poles	approx. weight ~kg
RLM E6-2528-2W-14	2.20	230/400	50	2890	—	7.60/4.40	76	4400	90 L	2	34
RLM E6-2528-2W-13	1.50	230/400	50	2890	—	5.30/3.05	69	4040	90 S	2	30
RLM E6-2528-2W-11	1.10	230/400	50	2860	—	3.90/2.25	63	3640	80 M	2	26
RLM E6-2528-2W-10	0.75	230/400	50	2870	—	2.95/1.71	55	3180	80 M	2	24
RLM E6-2528-2D-08	0.55	230/400	50	2800	—	2.37/1.36	51	2880	71 M	2	21
RLM E6-2528-BI-BW-L	3.00	380...480	50/60	4500	6.4	6.4...5.1	—	4400	90	—	32
RLM E6-2528-BE-AY-L	1.50	*	*	4500	3.2	3.2	—	3910	71	—	22
RLM E6-2528-BE-IG-M	1.30	*	*	3100	4.0	3.5	—	4000	108/30	—	18

* Motor for operation with inverter only (No mains operation).
We recommend: Danfoss VLT HVAC Drive FC-100.

Fan type code

- W = Asynchronous motor according to efficiency class IE2 (High Efficiency)
- BI = Brushless DC motor with integrated control unit (efficiency class IE3 and higher)
- BE = Brushless DC motor with external control unit (efficiency class IE3 and higher)

Dimensions in mm, subject to change.



Motor **	k _{max}	w
71	402	357
80	456	377
90	506	408

RLM E6-2528-2 -
RLM E6-2528-BI-_-L
RLM E6-2528-BE-_-L

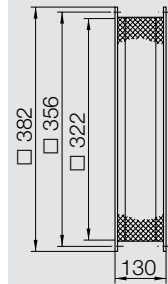

ZKE 15-1818

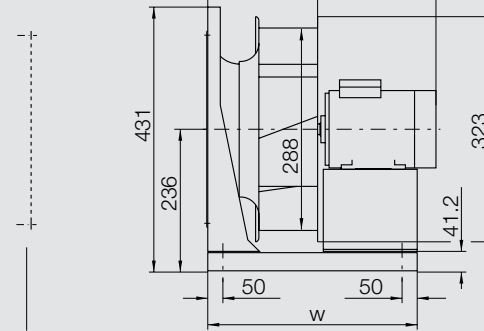

ZSG 04-0250

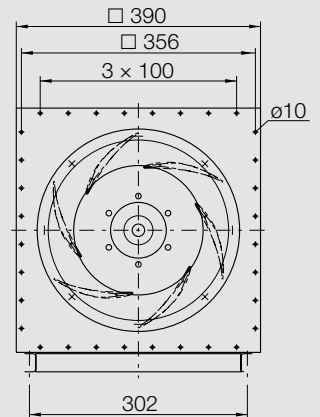

Dimensions in mm, subject to change.

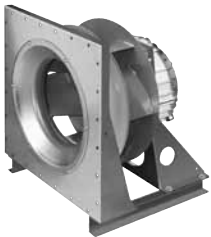

RLM E6-2528-BE-IG-M

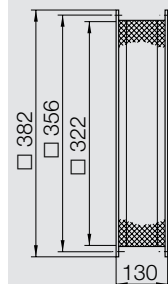

ZKE 15-1818

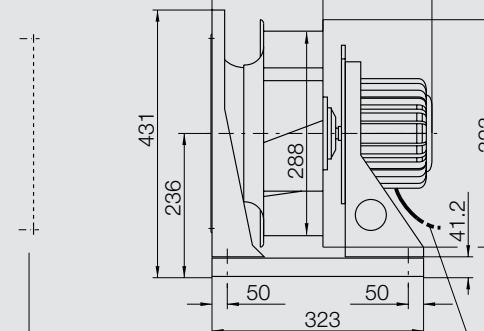

ZSG 04-0250

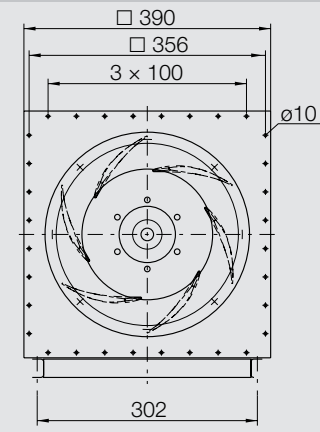

ø10 x 1500

RLM E6-2831

EVOLUTION
IS IN THE AIR
RLM^{EVO}

Technical Data

Fan type RLM Evo	Motor power kW (max.)	Mains voltage V	Mains frequency Hz	Nominal speed 1/min	Nominal moment Nm	Nominal current A	max. operating frequency Hz	max. speed 1/min	Motor size **	Poles	approx. weight ~kg
RLM E6-2831-2W-14	2.20	230/400	50	2890	–	7.60/4.40	65	3770	90 L	2	36
RLM E6-2831-2W-13	1.50	230/400	50	2890	–	5.30/3.05	57	3310	90 S	2	32
RLM E6-2831-2W-11	1.10	230/400	50	2860	–	3.90/2.25	52	2990	80 M	2	27
RLM E6-2831-4W-11	0.75	230/400	50	1400	–	3.15/1.81	94	2650	80 M	4	26
RLM E6-2831-4D-10	0.55	230/400	50	1395	–	2.54/1.46	83	2330	80 M	4	25
RLM E6-2831-BI-HL-L	2.20	380...480	50/60	3600	5.8	4.8...3.8	–	3600	90	–	34
RLM E6-2831-BE-GR-L	2.20	*	*	3600	5.8	4.6	–	3600	71	–	24
RLM E6-2831-BE-AY-L	1.50	*	*	4500	3.2	3.2	–	2950	71	–	23
RLM E6-2831-BE-IR-M	1.95	*	*	3100	6.0	4.5	–	3600	108/55	–	22

* Motor for operation with inverter only (No mains operation).
We recommend: Danfoss VLT HVAC Drive FC-100.

Fan type code

- W = Asynchronous motor according to efficiency class IE2 (High Efficiency)
- BI = Brushless DC motor with integrated control unit (efficiency class IE3 and higher)
- BE = Brushless DC motor with external control unit (efficiency class IE3 and higher)

Dimensions in mm, subject to change.



Motor **	k _{max}	w
71	422	397
80	476	397
90	526	428

RLM E6-2831-2 -
RLM E6-2831-4 -
RLM E6-2831-BI-__-L
RLM E6-2831-BE-__-L

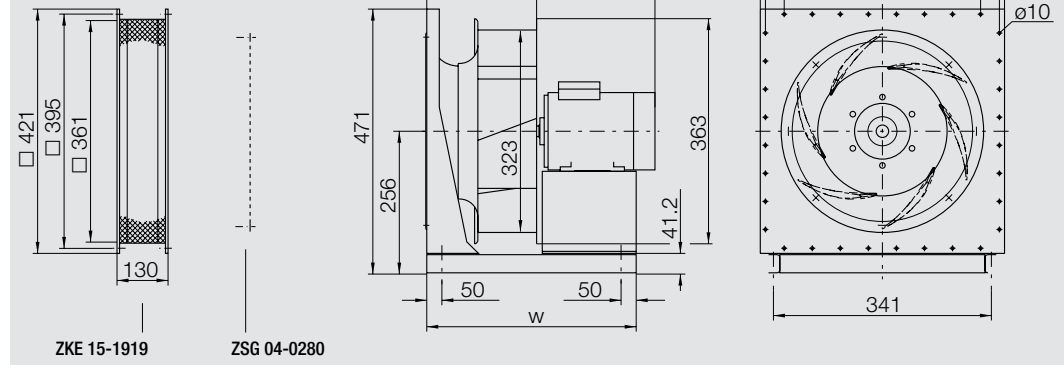

Dimensions in mm, subject to change.

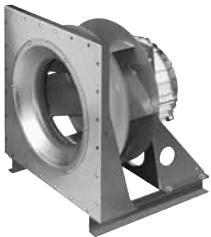

RLM E6-2831-BE-IR-M

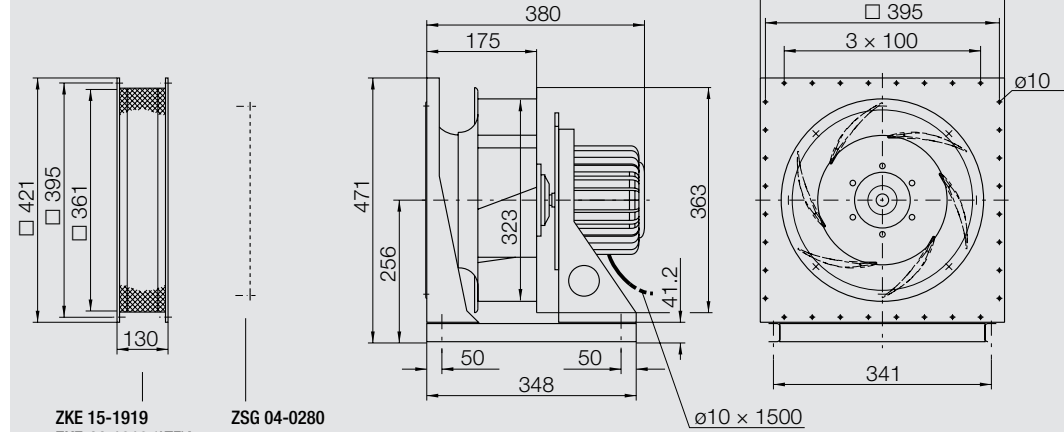

RLM E6-3135

Performance charts

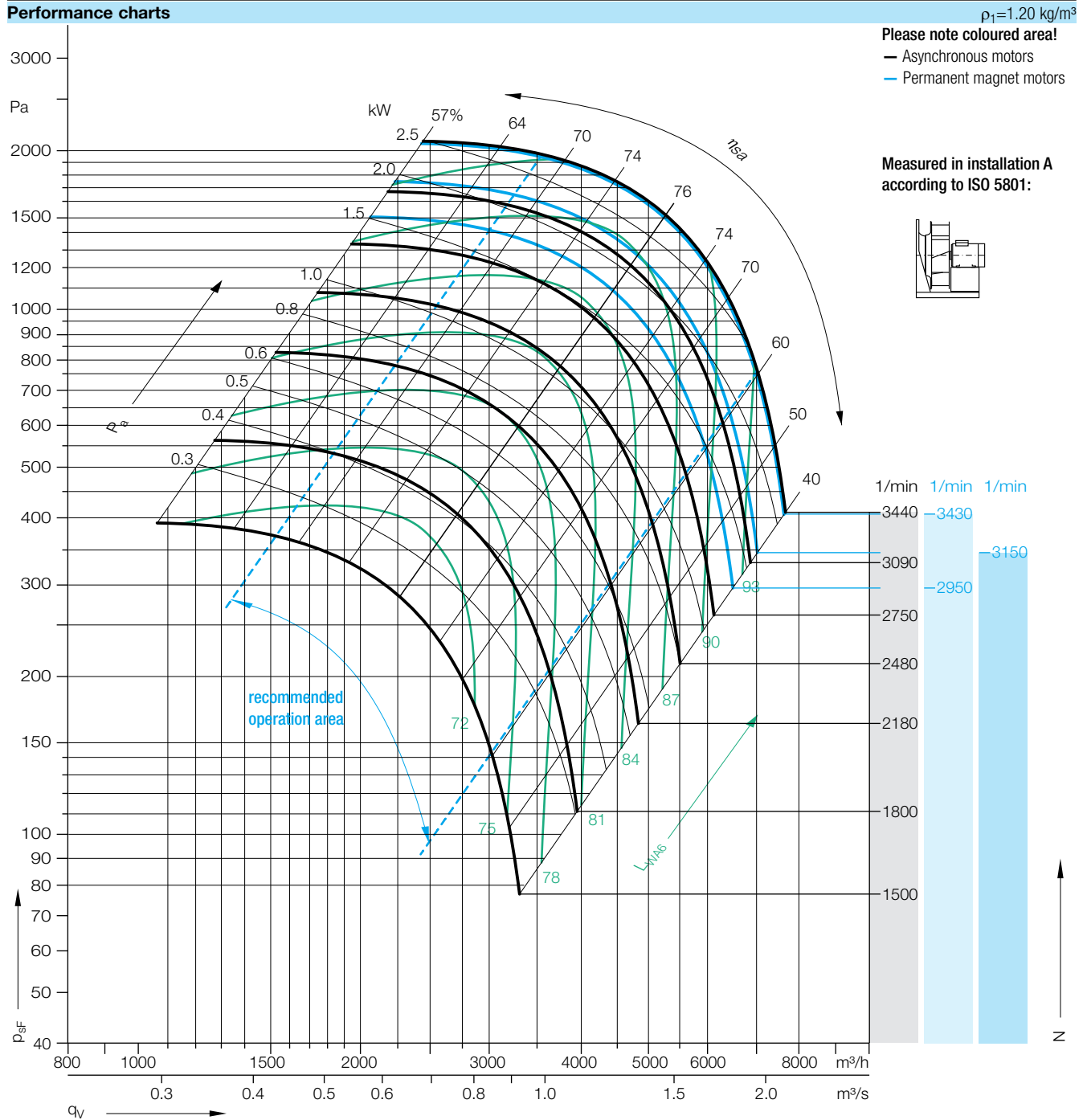

System efficiencies

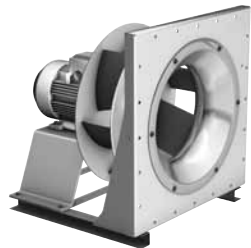

Comparison system efficiencies η_{se} (impeller, motor, inverter)

Model	Speed	η_{sa}	64	70	74	76	74	70	60	%
RLM E6-3135-		η_{sa}	64	70	74	76	74	70	60	%
2W-16	3440 1/min	η_{se}	53	57	61	62	61	57	49	%
BI-HN	3430 1/min	η_{se}	57	63	66	67	66	62	53	%
BE-HN	3430 1/min	η_{se}	57	63	66	67	66	62	53	%
BE-QG	3150 1/min	η_{se}	57	62	65	67	66	62	53	%

Formula symbols

- η_{se} = overall static efficiency (impeller, motor, inverter)
- η_{sa} = fan shaft static efficiency
- L_{WA6} = A-weighted sound power level at discharge
- P_a = fan shaft power

RLM E6-3135

EVOLUTION
IS IN THE AIR
RLM^{EVO}

Technical Data

Fan type RLM Evo	Motor power kW (max.)	Mains voltage V	Mains frequency Hz	Nominal speed 1/min	Nominal moment Nm	Nominal current A	max. operating frequency Hz	max. speed 1/min	Motor size **	Poles	approx. weight ~kg
RLM E6-3135-2W-16	3.00	400 Δ	50	2905	–	6.10	59	3440	100 L	2	40
RLM E6-3135-2W-14	2.20	230/400	50	2890	–	7.60/4.40	53	3090	90 L	2	38
RLM E6-3135-4W-14	1.50	230/400	50	1440	–	5.90/3.40	95	2750	90 L	4	34
RLM E6-3135-4W-13	1.10	230/400	50	1440	–	4.40/2.55	86	2480	90 S	4	33
RLM E6-3135-4W-11	0.75	230/400	50	1400	–	3.15/1.81	77	2180	80 M	4	30
RLM E6-3135-BI-HN-L	3.00	380...480	50/60	3600	8.0	6.4...5.1	–	3430	90	–	39
RLM E6-3135-BE-HN-L	3.00	*	*	3600	8.0	6.3	–	3430	90	–	32
RLM E6-3135-BE-GR-L	2.20	*	*	3600	5.8	4.6	–	2950	71	–	27
RLM E6-3135-BE-QG-M	2.10	*	*	2250	9.0	5.0	–	3150	150/45	–	31

* Motor for operation with inverter only (No mains operation).
We recommend: Danfoss VLT HVAC Drive FC-100.

Fan type code

- W = Asynchronous motor according to efficiency class IE2 (High Efficiency)
- BI = Brushless DC motor with integrated control unit (efficiency class IE3 and higher)
- BE = Brushless DC motor with external control unit (efficiency class IE3 and higher)

Dimensions in mm, subject to change.



RLM E6-3135-2W-
RLM E6-3135-4W-
RLM E6-3135-BI-__-L
RLM E6-3135-BE-__-L

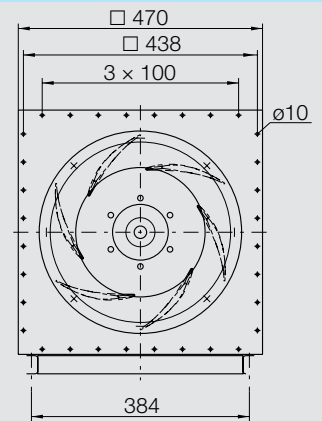
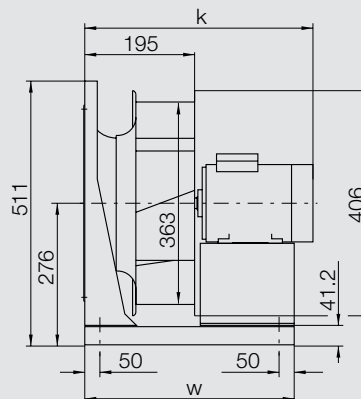
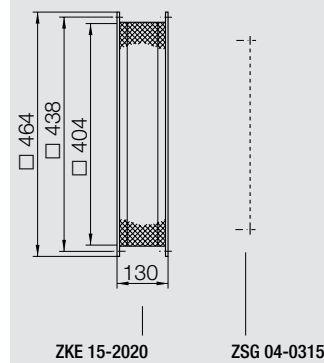

Motor **	k _{max}	w
71	442	417
80	496	417
90	546	448
100	563	470

Dimensions in mm, subject to change.



RLM E6-3135-BE-QG-M

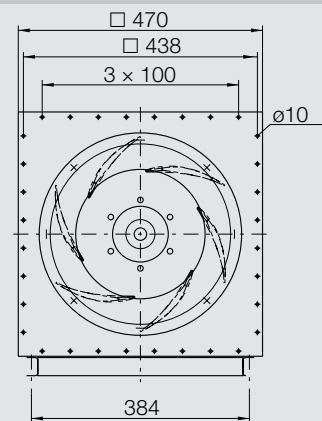
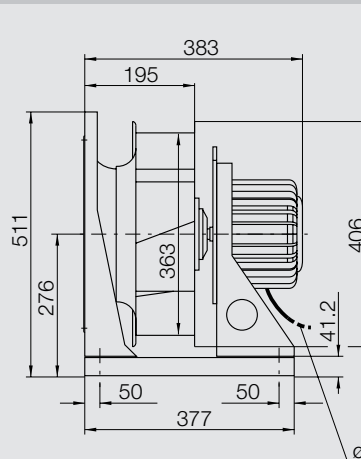
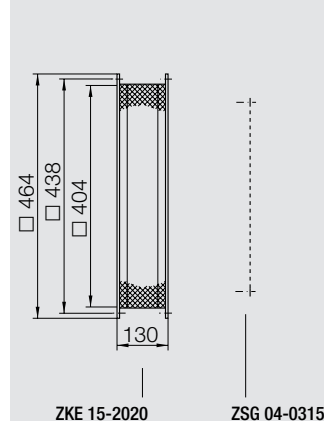

RLM E6-3540

Performance charts

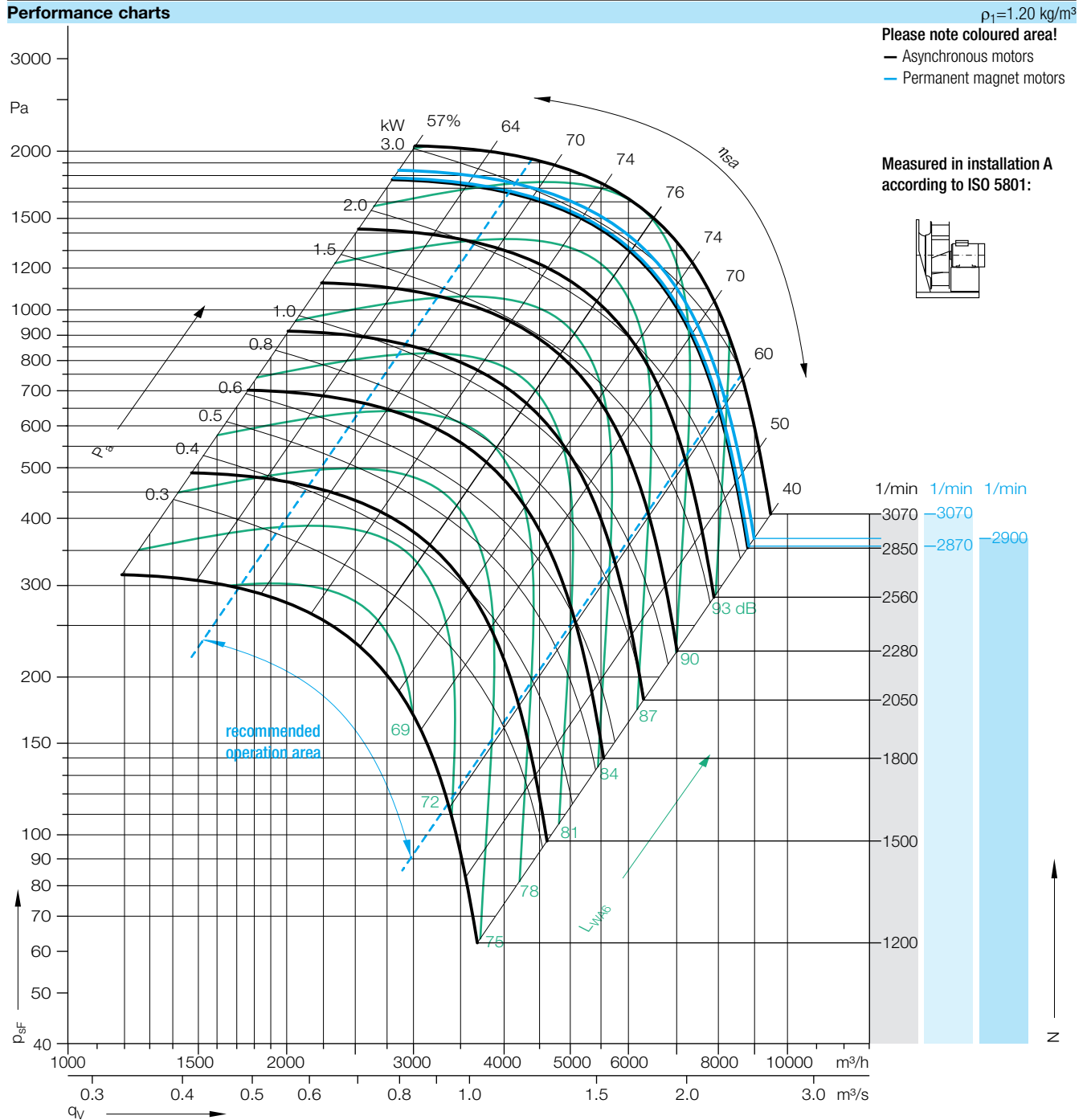

System efficiencies

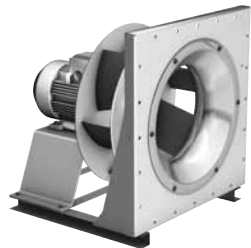

Comparison system efficiencies η_{se} (impeller, motor, inverter)

Model	Speed	Efficiency	64	70	74	76	74	70	60	%
RLM E6-3540-		η_{sa}				76				
2W-19	3070 1/min	η_{se}	53	58	62	63	62	58	50	%
BI-H3	2870 1/min	η_{se}	57	63	66	67	66	63	54	%
BE-H5	3070 1/min	η_{se}	57	63	66	67	66	63	54	%
BE-WT	2900 1/min	η_{se}	57	63	66	68	66	63	54	%

Formula symbols

- η_{se} = overall static efficiency (impeller, motor, inverter)
- η_{sa} = fan shaft static efficiency
- L_{WA6} = A-weighted sound power level at discharge
- P_a = fan shaft power

RLM E6-3540

EVOLUTION
IS IN THE AIR
RLM^{EVO}

Technical Data

Fan type RLM Evo	Motor power kW (max.)	Mains voltage V	Mains frequency Hz	Nominal speed 1/min	Nominal moment Nm	Nominal current A	max. operating frequency Hz	max. speed 1/min	Motor size **	Poles	approx. weight ~kg
RLM E6-3540-2W-19	4.00	400 Δ	50	2950	–	7.80	52	3070	112 M	2	54
RLM E6-3540-4W-17	3.00	400 Δ	50	1455	–	6.20	97	2850	100 L	4	58
RLM E6-3540-4W-16	2.20	400 Δ	50	1455	–	4.65	87	2560	100 L	4	49
RLM E6-3540-4W-14	1.50	230/400	50	1440	–	5.90/3.40	79	2280	90 L	4	44
RLM E6-3540-4W-13	1.10	230/400	50	1440	–	4.40/2.55	71	2050	90 S	4	41
RLM E6-3540-4W-11	0.75	230/400	50	1400	–	3.15/1.81	64	1800	80 M	4	37
RLM E6-3540-BI-H3-L	3.00	380...480	50/60	3000	9.6	6.4...5.1	–	2870	90	–	46
RLM E6-3540-BE-H5-L	4.00	*	*	3000	12.7	8.5	–	3070	90	–	41
RLM E6-3540-BE-H3-L	3.00	*	*	3000	9.6	6.4	–	2870	90	–	39
RLM E6-3540-BE-WT-M	2.80	*	*	1900	14.0	7.0	–	2900	150/70	–	39

* Motor for operation with inverter only (No mains operation).
We recommend: Danfoss VLT HVAC Drive FC-100.

Fan type code

- W = Asynchronous motor according to efficiency class IE2 (High Efficiency)
- BI = Brushless DC motor with integrated control unit (efficiency class IE3 and higher)
- BE = Brushless DC motor with external control unit (efficiency class IE3 and higher)

Dimensions in mm, subject to change.



Motor **	k _{max}	w
80	526	447
90	576	478
100	593	500
112	586	507

RLM E6-3540-2W-
RLM E6-3540-4W-
RLM E6-3540-BI-__-L
RLM E6-3540-BE-__-L

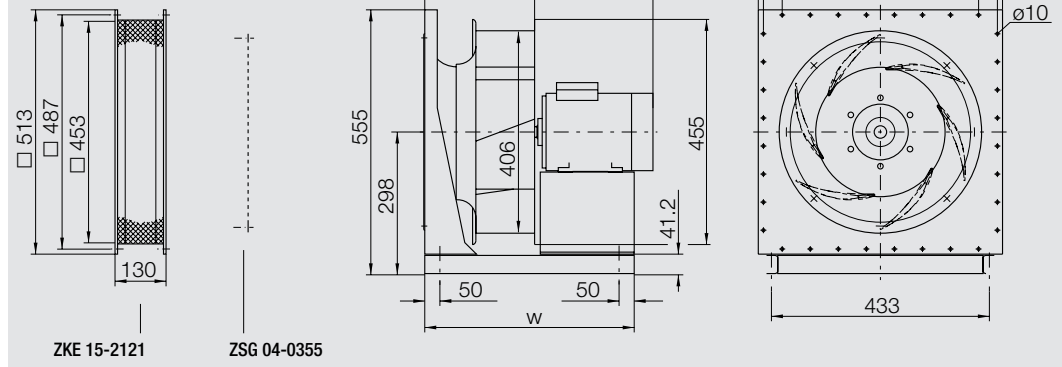

Dimensions in mm, subject to change.



RLM E6-3540-BE-WT-M

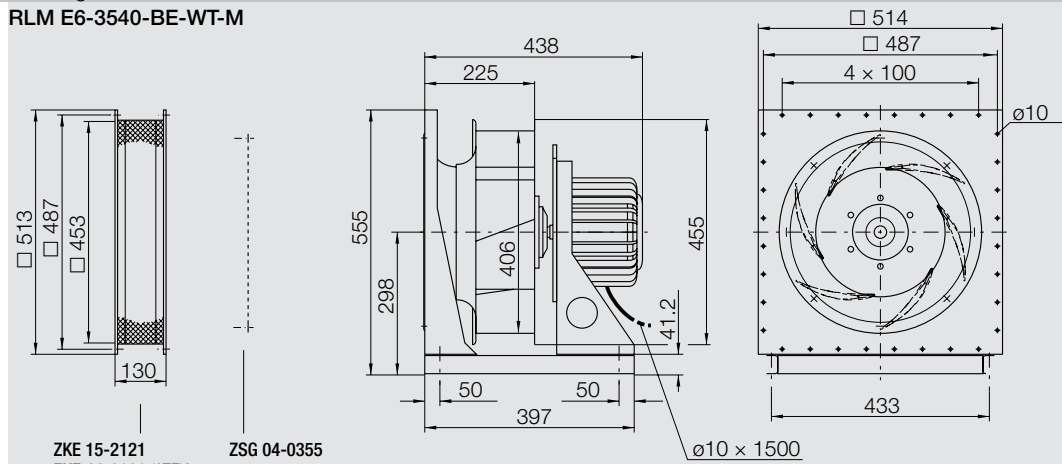

RLM E6-4045

Performance charts

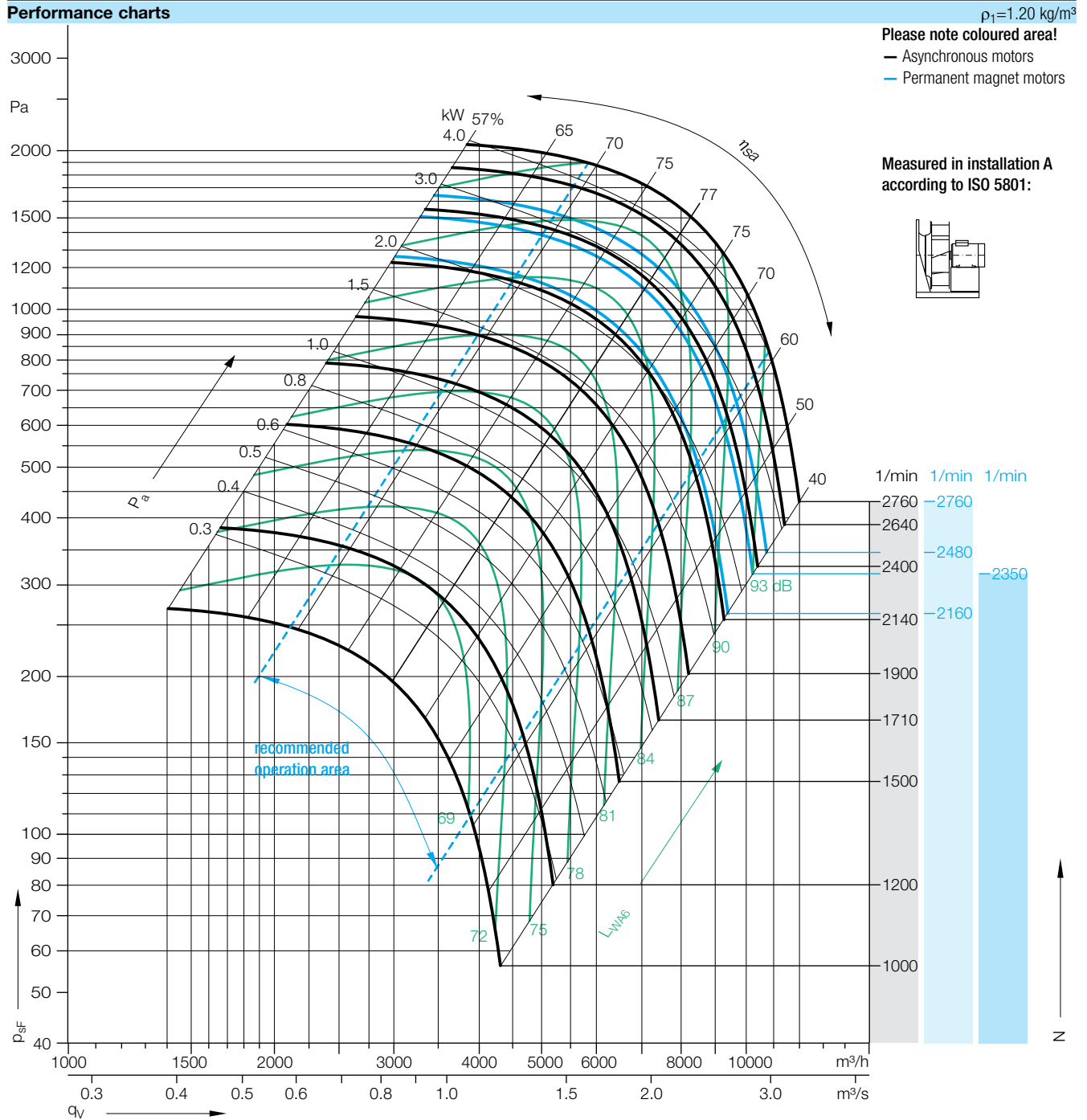

System efficiencies

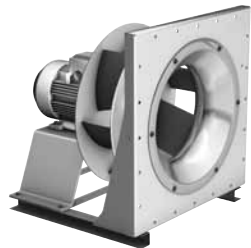

Comparison system efficiencies η_{se} (impeller, motor, inverter)

Model	Speed (1/min)	Efficiency Type	65	70	75	77	75	70	60	%
RLM E6-4045-		η_{sa}	65	70	75	77	75	70	60	%
4W-21	2760	η_{se}	55	60	64	65	64	60	51	%
BI-H5	2480	η_{se}	58	63	67	68	67	63	54	%
BE-H7	2760	η_{se}	58	63	67	68	67	63	54	%
BE-WT	2350	η_{se}	58	63	68	69	68	63	54	%

Formula symbols

- η_{se} = overall static efficiency (impeller, motor, inverter)
- η_{sa} = fan shaft static efficiency
- L_{WA6} = A-weighted sound power level at discharge
- P_a = fan shaft power

RLM E6-4045

EVOLUTION
IS IN THE AIR
RLM^{EVO}

Technical Data

Fan type RLM Evo	Motor power kW (max.)	Mains voltage V	Mains frequency Hz	Nominal speed 1/min	Nominal moment Nm	Nominal current A	max. operating frequency Hz	max. speed 1/min	Motor size **	Poles	approx. weight ~kg
RLM E6-4045-4W-21	5.5	400 Δ	50	1465	–	11.4	94	2760	132 S	4	77
RLM E6-4045-4W-19	4.0	400 Δ	50	1460	–	8.20	90	2640	112 M	4	66
RLM E6-4045-4W-17	3.0	400 Δ	50	1455	–	6.20	82	2400	100 L	4	64
RLM E6-4045-4W-16	2.2	400 Δ	50	1455	–	4.65	73	2140	100 L	4	54
RLM E6-4045-4W-14	1.5	230/400	50	1440	–	5.90/3.40	65	1900	90 L	4	50
RLM E6-4045-4W-13	1.1	230/400	50	1440	–	4.40/2.55	59	1710	90 S	4	46
RLM E6-4045-BI-H5-L	4.00	380...480	50/60	3000	12.7	8.5...6.8	–	2480	90	–	53
RLM E6-4045-BE-H7-L	5.50	*	*	3000	17.5	11.7	–	2760	90	–	48
RLM E6-4045-BE-H5-L	4.00	*	*	3000	12.7	8.5	–	2480	90	–	46
RLM E6-4045-BE-H3-L	3.00	*	*	3000	9.6	6.4	–	2160	90	–	44
RLM E6-4045-BE-WT-M	2.80	*	*	1900	14.0	7.0	–	2350	150/70	–	44

* Motor for operation with inverter only (No mains operation).
We recommend: Danfoss VLT HVAC Drive FC-100.

Fan type code

- W = Asynchronous motor according to efficiency class IE2 (High Efficiency)
- BI = Brushless DC motor with integrated control unit (efficiency class IE3 and higher)
- BE = Brushless DC motor with external control unit (efficiency class IE3 and higher)

Dimensions



Motor **	k _{max}	w
90	601	503
100	618	525
112	611	532
132	667	561

RLM E6-4045-4W-
RLM E6-4045-BI-_-L
RLM E6-4045-BE-_-L

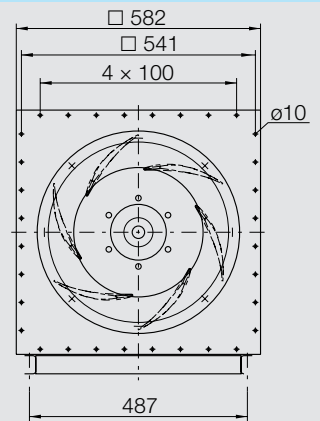
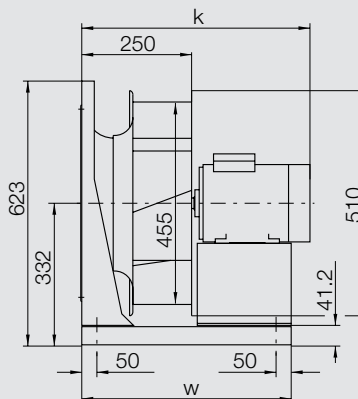
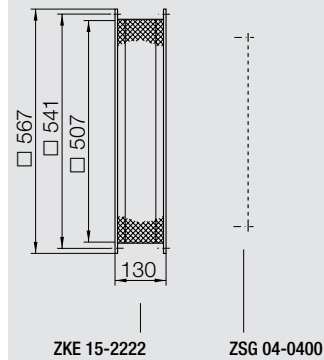

Dimensions in mm, subject to change.

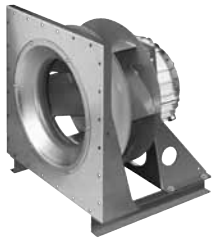

RLM E6-4045-BE-WT-M

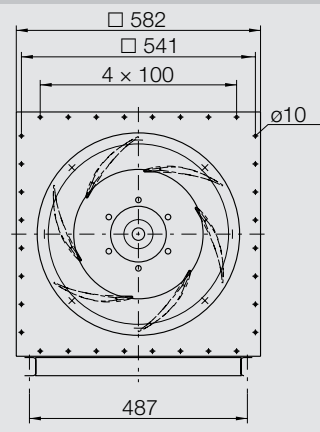
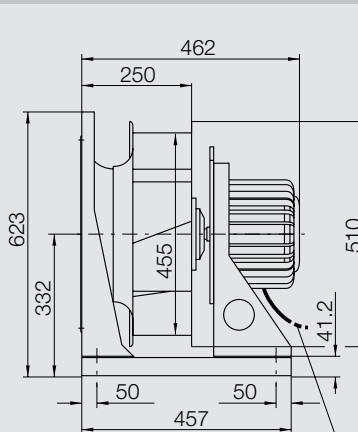
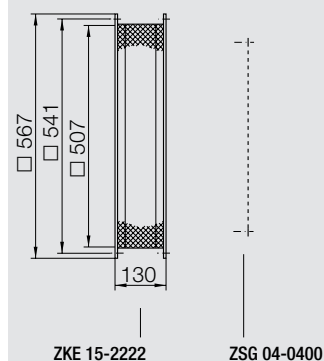

RLM E6-4550

EVOLUTION
IS IN THE AIR
RLM^{EVO}

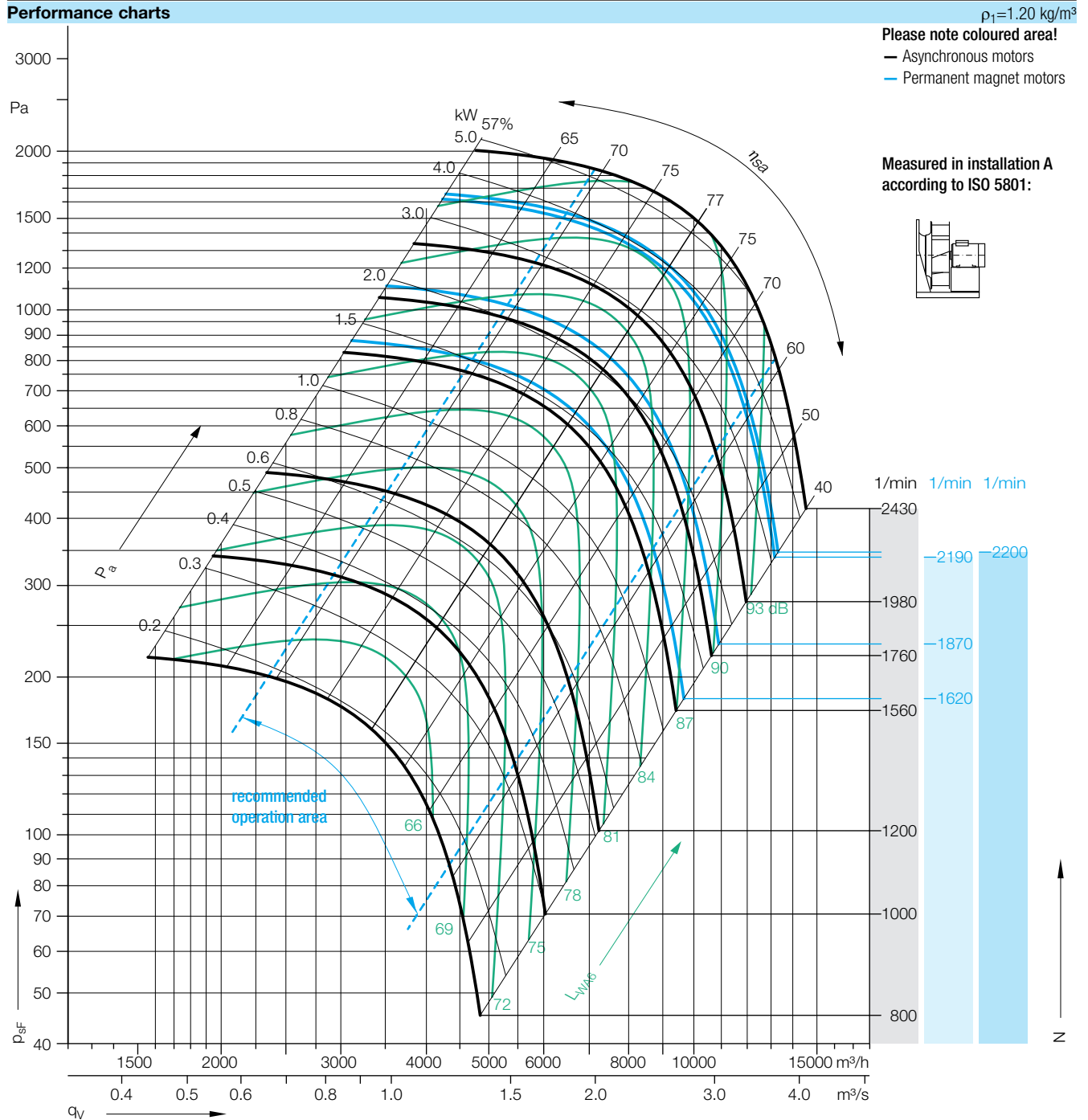

System efficiencies

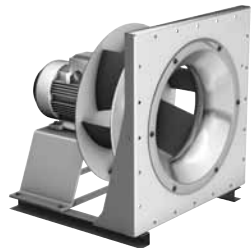

Comparison system efficiencies η_{se} (impeller, motor, inverter)

Model	Flow Rate	Efficiency Type	65	70	75	77	75	70	60	%
RLM E6-4550-		η_{sa}	65	70	75	77	75	70	60	%
4W-21	2430 1/min	η_{se}	55	60	64	65	64	60	51	%
BI-H7	2190 1/min	η_{se}	58	63	67	68	67	63	54	%
BE-H7	2190 1/min	η_{se}	58	63	67	68	67	63	54	%
BE-YG	2200 1/min	η_{se}	58	63	68	69	68	63	54	%

Formula symbols

- η_{se} = overall static efficiency (impeller, motor, inverter)
- η_{sa} = fan shaft static efficiency
- L_{WA6} = A-weighted sound power level at discharge
- P_a = fan shaft power

RLM E6-4550

EVOLUTION
IS IN THE AIR
RLM^{EVO}

Technical Data

Fan type RLM Evo	Motor power kW (max.)	Mains voltage V	Mains frequency Hz	Nominal speed 1/min	Nominal moment Nm	Nominal current A	max. operating frequency Hz	max. speed 1/min	Motor size **	Poles	approx. weight ~kg
RLM E6-4550-4W-21	5.5	400 Δ	50	1465	–	11.40	82	2430	132 S	4	88
RLM E6-4550-4W-19	4.0	400 Δ	50	1460	–	8.20	74	2180	112 M	4	77
RLM E6-4550-4W-17	3.0	400 Δ	50	1455	–	6.20	68	1980	100 L	4	71
RLM E6-4550-4W-16	2.2	400 Δ	50	1455	–	4.65	60	1760	100 L	4	62
RLM E6-4550-4W-14	1.5	230/400	50	1440	–	5.90/3.4	54	1560	90 L	4	57
RLM E6-4550-BI-H7-L	5.50	380...480	50/60	3000	17.5	11.7...9.3	–	2190	90	–	63
RLM E6-4550-BE-H7-L	5.50	*	*	3000	17.5	11.7	–	2190	90	–	56
RLM E6-4550-BE-H5-L	4.00	*	*	3000	12.7	8.5	–	1870	90	–	54
RLM E6-4550-BE-H3-L	3.00	*	*	3000	9.6	6.4	–	1620	90	–	52
RLM E6-4550-BE-YG-M	4.30	*	*	1700	24.0	10.0	–	2200	220/55	–	67

* Motor for operation with inverter only (No mains operation).
We recommend: Danfoss VLT HVAC Drive FC-100.

Fan type code

- W = Asynchronous motor according to efficiency class IE2 (High Efficiency)
- BI = Brushless DC motor with integrated control unit (efficiency class IE3 and higher)
- BE = Brushless DC motor with external control unit (efficiency class IE3 and higher)

Dimensions in mm, subject to change.



RLM E6-4550-4W-
RLM E6-4550-BI-__-L
RLM E6-4550-BE-__-L

Motor **	k _{max}	w
90	628	530
100	645	552
112	638	559
132	694	598

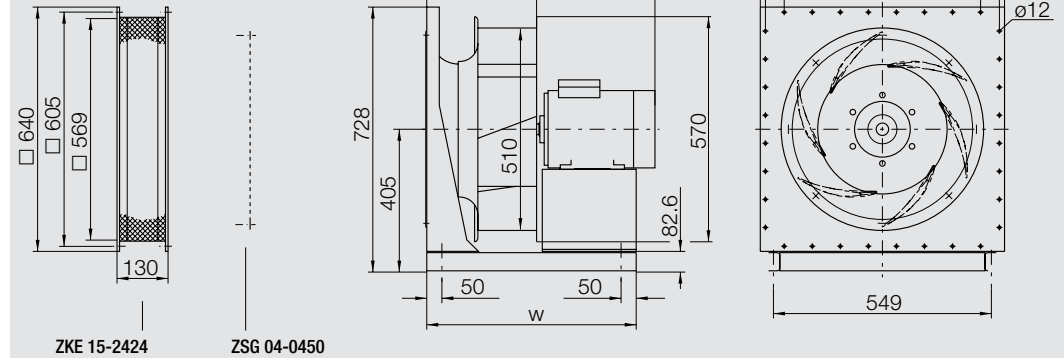

Dimensions in mm, subject to change.

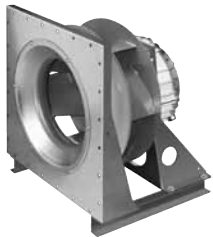

RLM E6-4550-BE-YG-M

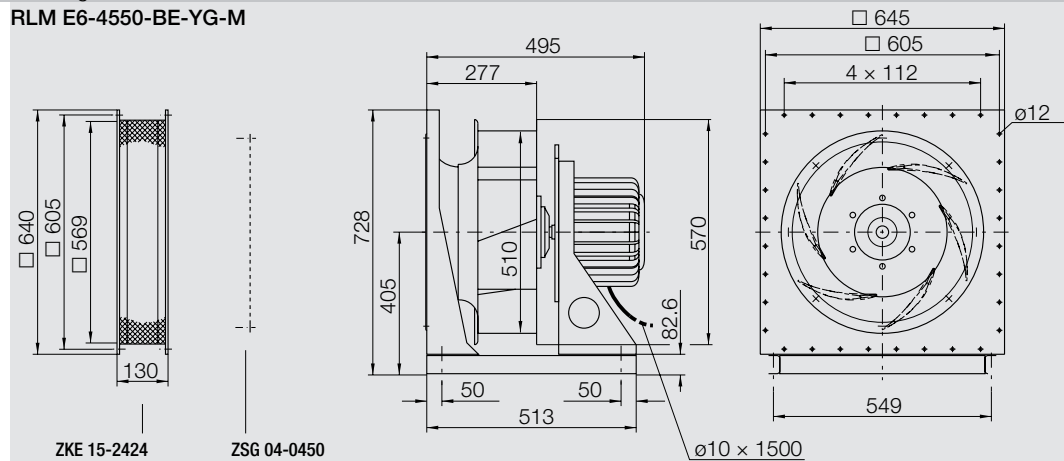

RLM E6-5056

Performance charts

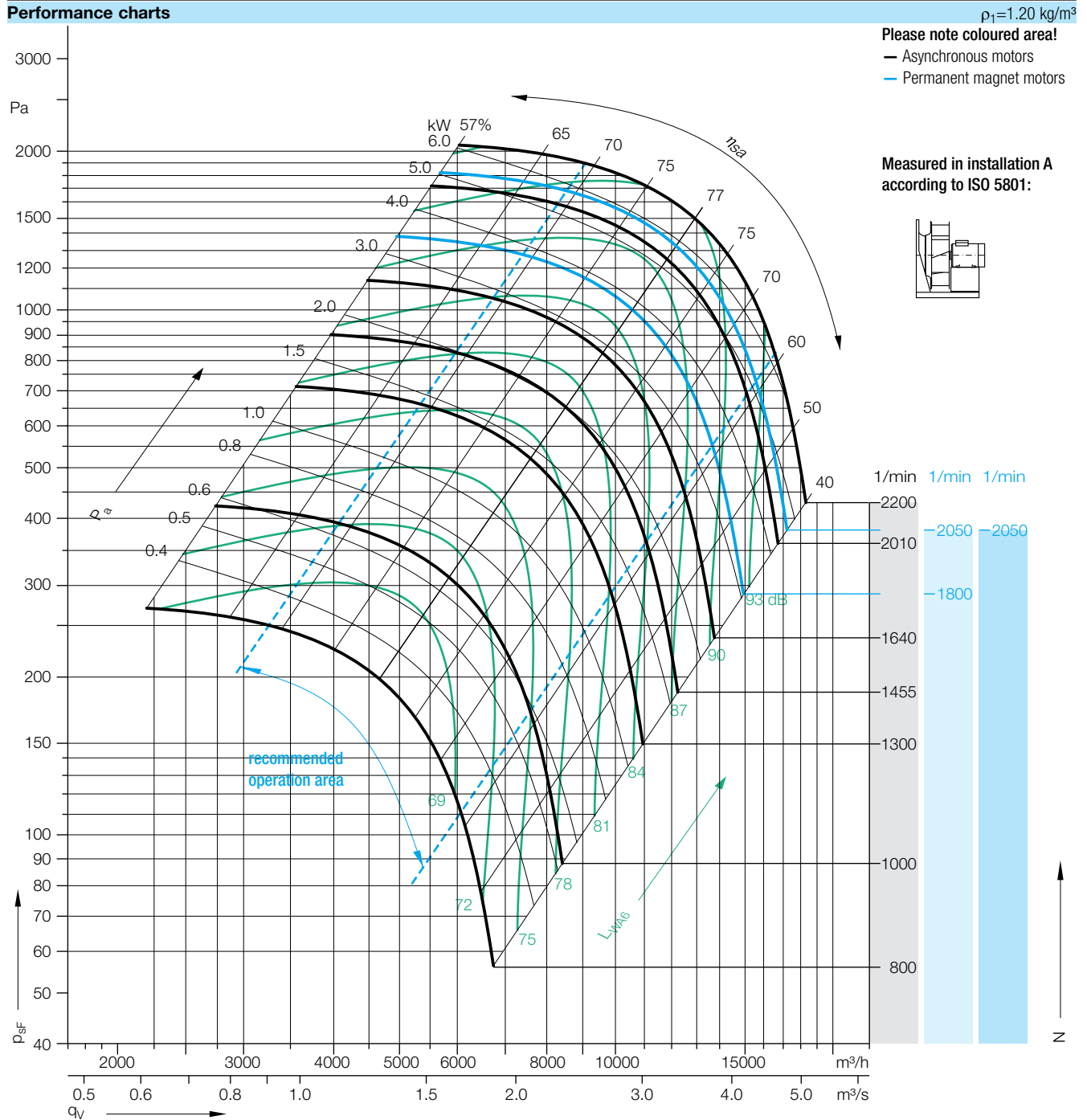

System efficiencies

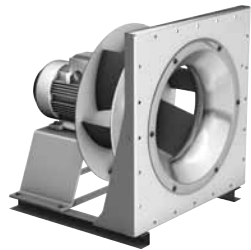

Comparison system efficiencies η_{se} (impeller, motor, inverter)

Model	Speed (1/min)	η_{sa}	65	70	75	77	75	70	60	%
RLM E6-5056-		η_{sa}	65	70	75	77	75	70	60	%
4W-23	2200	η_{se}	56	61	65	66	65	61	52	%
BI-UR	1800	η_{se}	57	62	66	67	66	62	53	%
BE-VN	2050	η_{se}	58	63	67	68	67	63	54	%
BE-YN	2050	η_{se}	58	63	68	69	68	63	54	%

Formula symbols

- η_{se} = overall static efficiency (impeller, motor, inverter)
- η_{sa} = fan shaft static efficiency
- L_{WA6} = A-weighted sound power level at discharge
- P_a = fan shaft power

RLM E6-5056

EVOLUTION
IS IN THE AIR
RLM^{EVO}

Technical Data

Fan type RLM Evo	Motor power kW (max.)	Mains voltage V	Mains frequency Hz	Nominal speed 1/min	Nominal moment Nm	Nominal current A	max. operating frequency Hz	max. speed 1/min	Motor size **	Poles	approx. weight ~kg
RLM E6-5056-4W-23	7.5	400 Δ	50	1465	–	14.80	75	2200	132 M	4	113
RLM E6-5056-4W-21	5.5	400 Δ	50	1465	–	11.40	68	2010	132 S	4	100
RLM E6-5056-4W-19	4.0	400 Δ	50	1460	–	8.20	61	1800	112 M	4	87
RLM E6-5056-4W-17	3.0	400 Δ	50	1455	–	6.20	56	1640	100 L	4	81
RLM E6-5056-4W-16	2.2	400 Δ	50	1455	–	4.65	50	1455	100 L	4	72
RLM E6-5056-6W-16	1.5	230/400	50	935	–	6.40/3.7	69	1300	100 L	6	78
RLM E6-5056-BI-UR-L	4.00	380...480	50/60	1800	21.2	8.8...7.0	–	1800	90	–	82
RLM E6-5056-BE-VN-L	5.50	*	*	1800	29.2	11.6	–	2050	112	–	84
RLM E6-5056-BE-YN-M	6.50	*	*	1400	44.0	16.0	–	2050	220/100	–	90

* Motor for operation with inverter only (No mains operation).
We recommend: Danfoss VLT HVAC Drive FC-100.

Fan type code

- W = Asynchronous motor according to efficiency class IE2 (High Efficiency)
- BI = Brushless DC motor with integrated control unit (efficiency class IE3 and higher)
- BE = Brushless DC motor with external control unit (efficiency class IE3 and higher)

Dimensions in mm, subject to change.



Motor **	k _{max}	w
90	638	540
100	666	562
112	648	569
132	704	608

RLM E6-5056-4W-
RLM E6-5056-6W-
RLM E6-5056-BI-__-L
RLM E6-5056-BE-__-L

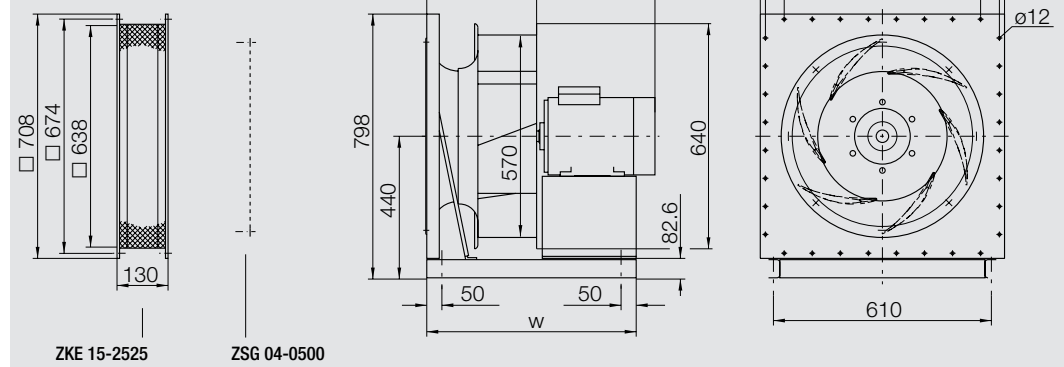

Dimensions in mm, subject to change.

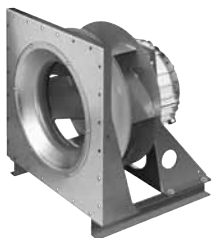

RLM E6-5056-BE-YN-M

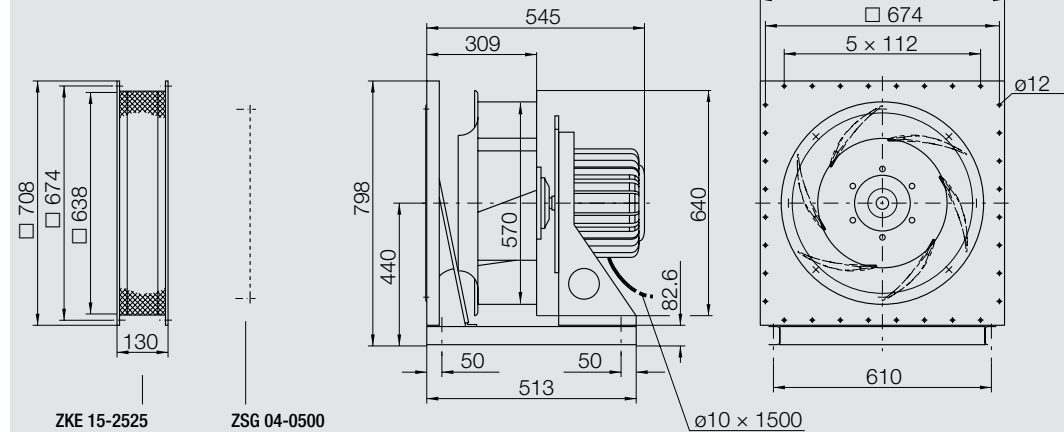

RLM E6-5663

Performance charts

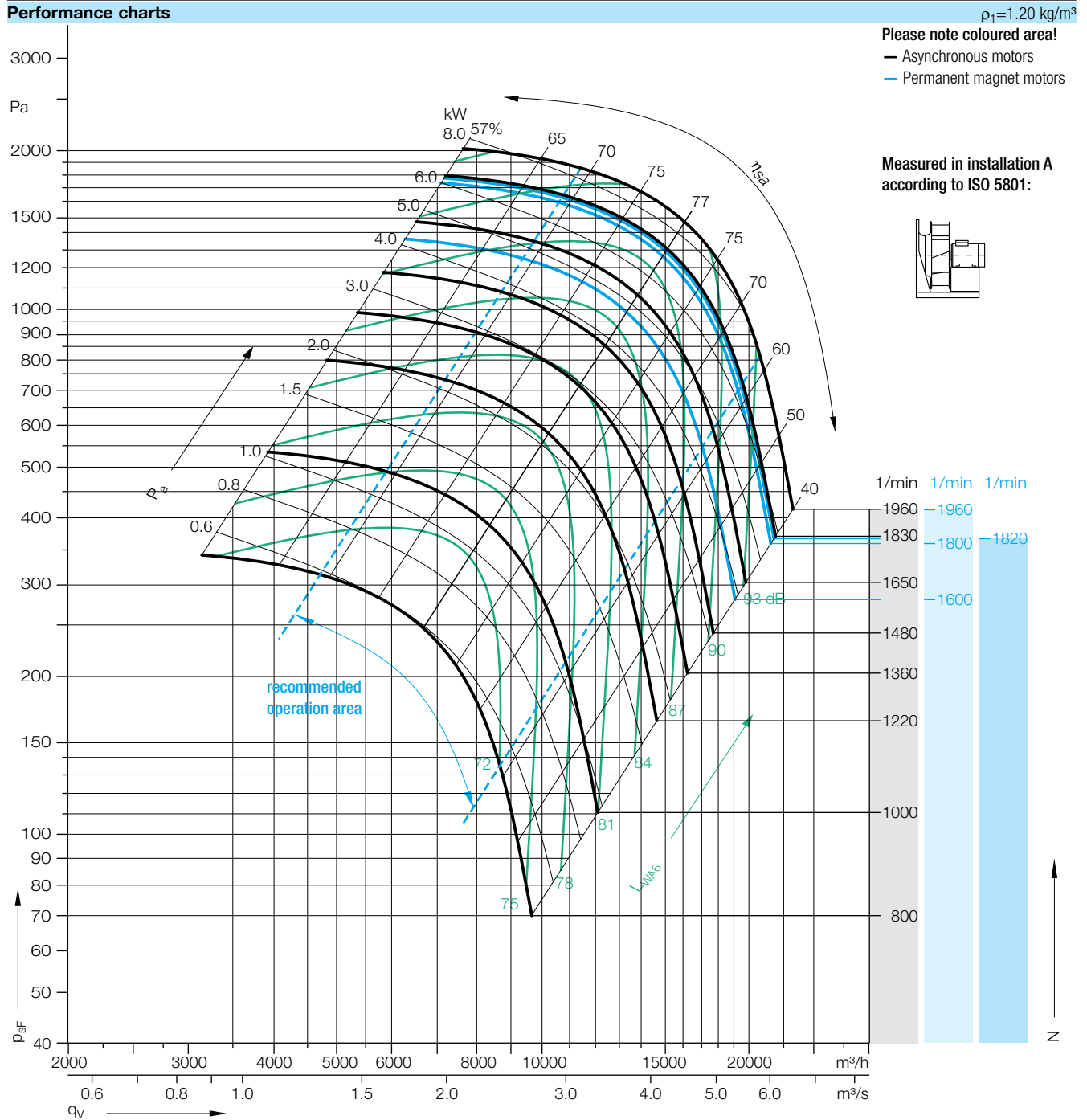

System efficiencies

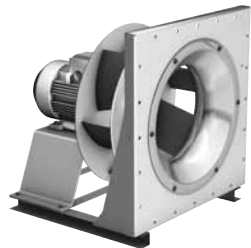

Comparison system efficiencies η_{se} (impeller, motor, inverter)

Model	Speed	Efficiency	65	70	75	77	75	70	60	Unit
RLM E6-5663-		η_{sa}	65	70	75	77	75	70	60	%
4W-26	1960 1/min	η_{se}	57	61	66	67	66	61	53	%
BI-VP	1800 1/min	η_{se}	58	63	67	68	67	63	54	%
BE-VR	1960 1/min	η_{se}	58	63	67	68	67	63	54	%
BE-YN	1820 1/min	η_{se}	58	63	68	69	68	63	54	%

Formula symbols

- η_{se} = overall static efficiency (impeller, motor, inverter)
- η_{sa} = fan shaft static efficiency
- L_{WA6} = A-weighted sound power level at discharge
- P_a = fan shaft power

RLM E6-5663

EVOLUTION
IS IN THE AIR
RLM^{EVO}

Technical Data

Fan type RLM Evo	Motor power kW (max.)	Mains voltage V	Mains frequency Hz	Nominal speed 1/min	Nominal moment Nm	Nominal current A	max. operating frequency Hz	max. speed 1/min	Motor size **	Poles	approx. weight ~kg
RLM E6-5663-4W-26	11.0	400 Δ	50	1470	–	21.0	66	1960	160 M	4	146
RLM E6-5663-4W-23	7.5	400 Δ	50	1465	–	14.8	62	1830	132 M	4	123
RLM E6-5663-4W-21	5.5	400 Δ	50	1465	–	11.4	56	1650	132 S	4	110
RLM E6-5663-4W-19	4.0	400 Δ	50	1460	–	8.2	50	1480	112 M	4	99
RLM E6-5663-6W-21	3.0	400 Δ	50	970	–	7.0	70	1360	132 S	6	101
RLM E6-5663-6W-19	2.2	400 Δ	50	955	–	5.6	63	1220	112 M	6	100
RLM E6-5663-BI-VP-L	7.50	380...480	50/60	1800	39.8	16.2...12.8	–	1800	112	–	107
RLM E6-5663-BE-VR-L	11.00	*	*	1800	58.4	23.2	–	1960	112	–	103
RLM E6-5663-BE-VP-L	7.50	*	*	1800	39.8	15.8	–	1800	112	–	100
RLM E6-5663-BE-VN-L	5.50	*	*	1800	29.2	11.6	–	1600	112	–	96
RLM E6-5663-BE-YN-M	6.50	*	*	1400	44.0	16.0	–	1820	220/100	–	99

* Motor for operation with inverter only (No mains operation).
We recommend: Danfoss VLT HVAC Drive FC-100.

Fan type code

- W = Asynchronous motor according to efficiency class IE2 (High Efficiency)
- BI = Brushless DC motor with integrated control unit (efficiency class IE3 and higher)
- BE = Brushless DC motor with external control unit (efficiency class IE3 and higher)

Dimensions in mm, subject to change.



Motor **	k _{max}	w
112	757	615
132	745	649
160	854	748

RLM E6-5663-4W-
RLM E6-5663-6W-
RLM E6-5663-BI-_-L
RLM E6-5663-BE-_-L

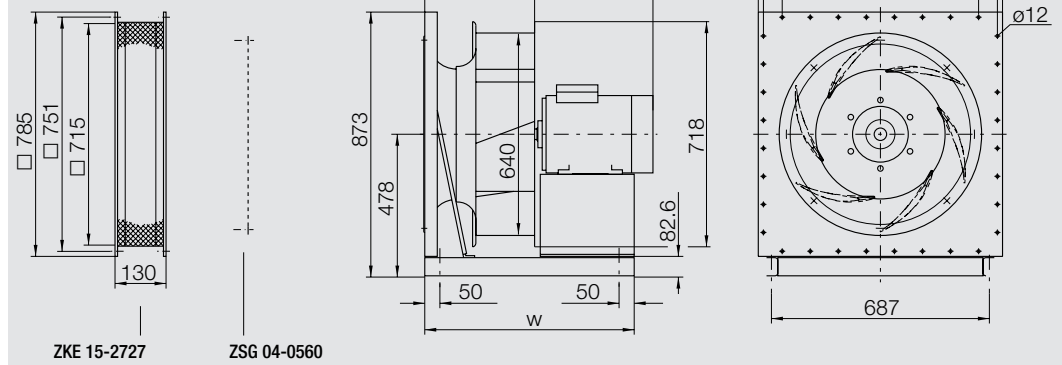

Dimensions in mm, subject to change.

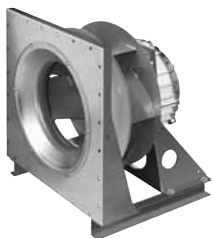

RLM E6-5663-BE-YN-M

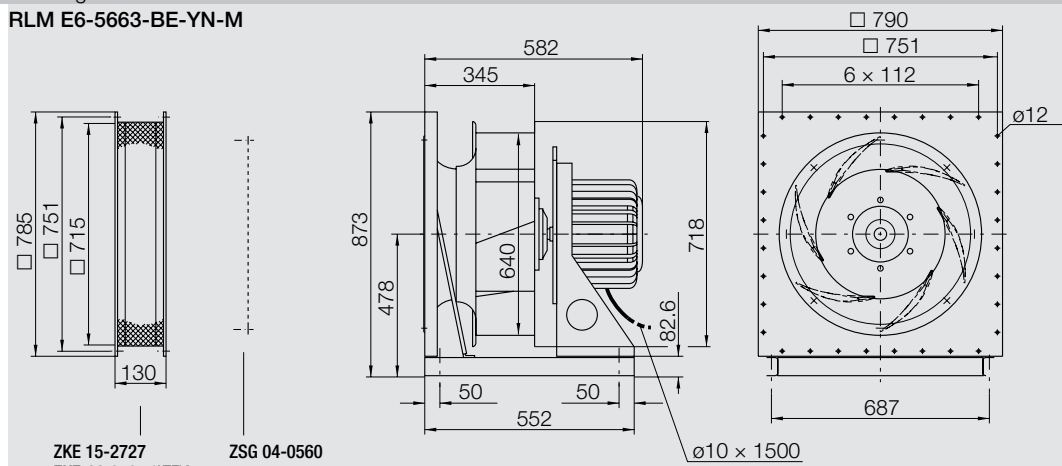

RLM E6-6371

Performance charts

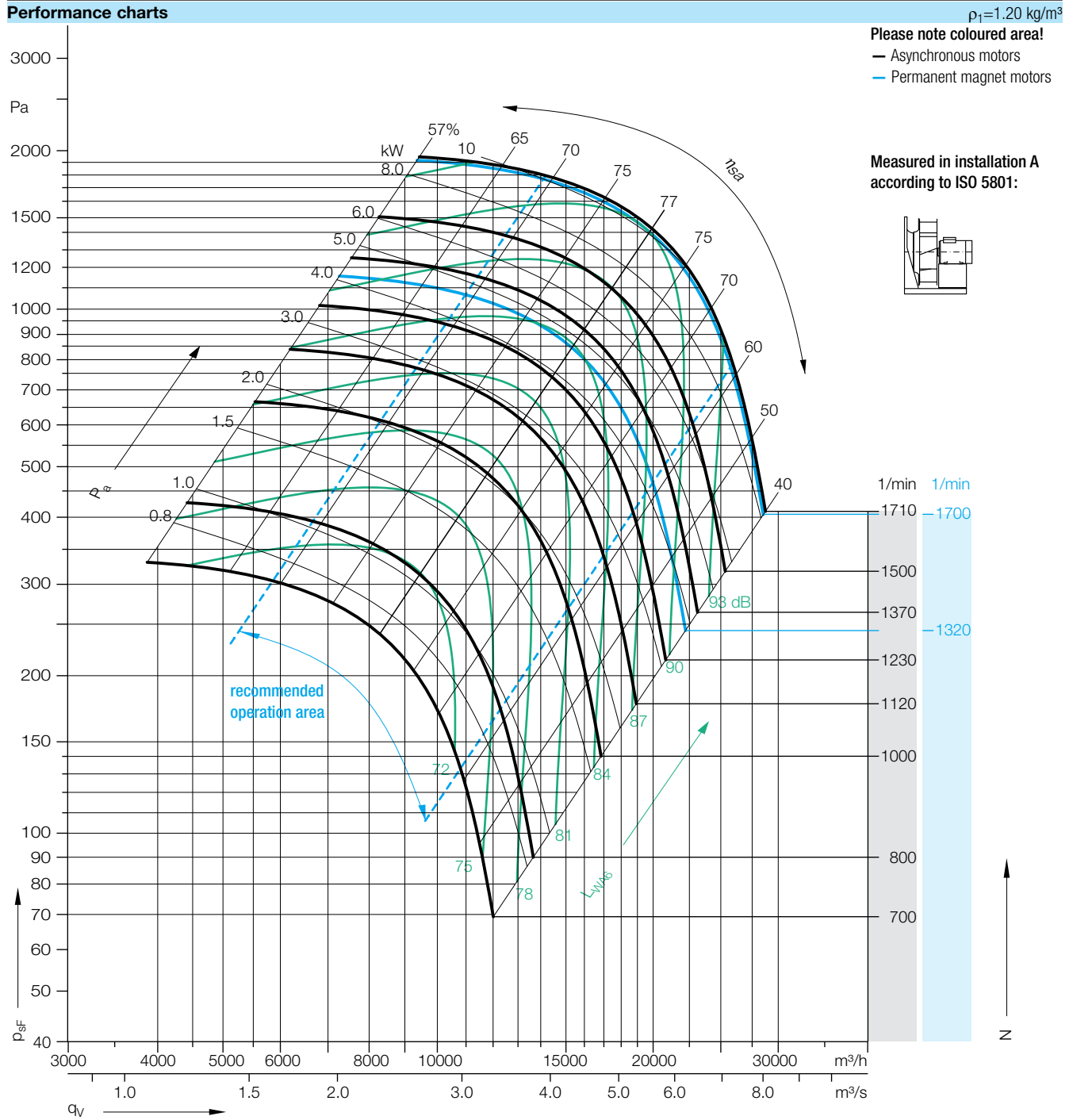

System efficiencies

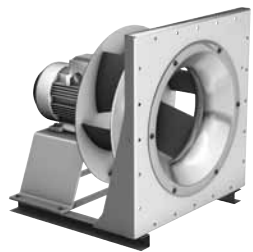

Comparison system efficiencies η_{se} (impeller, motor, inverter)

Model	Speed	Efficiency	65	70	75	77	75	70	60	Unit
RLM E6-6371-		η_{sa}	65	70	75	77	75	70	60	%
4W-26	1710 1/min	η_{se}	57	61	66	67	66	61	53	%
BI-VR	1700 1/min	η_{se}	58	63	67	68	67	63	54	%
BE-VR	1700 1/min	η_{se}	58	63	67	68	67	63	54	%

Formula symbols

- η_{se} = overall static efficiency (impeller, motor, inverter)
- η_{sa} = fan shaft static efficiency
- L_{WA6} = A-weighted sound power level at discharge
- P_a = fan shaft power

RLM E6-6371

EVOLUTION
IS IN THE AIR
RLM^{EVO}

Technical Data

Fan type RLM Evo	Motor power kW (max.)	Mains voltage V	Mains frequency Hz	Nominal speed 1/min	Nominal moment Nm	Nominal current A	max. operating frequency Hz	max. speed 1/min	Motor size **	Poles	approx. weight ~kg
RLM E6-6371-4W-26	11.0	400 Δ	50	1470	–	21.0	58	1710	160 M	4	171
RLM E6-6371-4W-23	7.5	400 Δ	50	1465	–	14.8	51	1500	132 M	4	144
RLM E6-6371-6W-24	5.5	400 Δ	50	970	–	12.0	70	1370	132 M	6	150
RLM E6-6371-6W-23	4.0	400 Δ	50	970	–	8.7	63	1230	132 M	6	135
RLM E6-6371-6W-21	3.0	400 Δ	50	970	–	7.0	57	1120	132 S	6	124
RLM E6-6371-BI-VR-L	11.0	380...480	50/60	1800	58.4	23.6...18.7	–	1700	112	–	135
RLM E6-6371-BE-VR-L	11.0	*	*	1800	58.4	23.2	–	1700	112	–	128
RLM E6-6371-BE-VP-L	7.5	*	*	1800	39.8	15.8	–	1320	112	–	125

* Motor for operation with inverter only (No mains operation).

We recommend: Danfoss VLT HVAC Drive FC-100.

Fan type code

W = Asynchronous motor according to efficiency class IE2 (High Efficiency)

BI = Brushless DC motor with integrated control unit (efficiency class IE3 and higher)

BE = Brushless DC motor with external control unit (efficiency class IE3 and higher)

Dimensions in mm, subject to change.



Motor **	k _{max}	w
112	800	692
132	814	692
160	897	791

RLM E6-6371

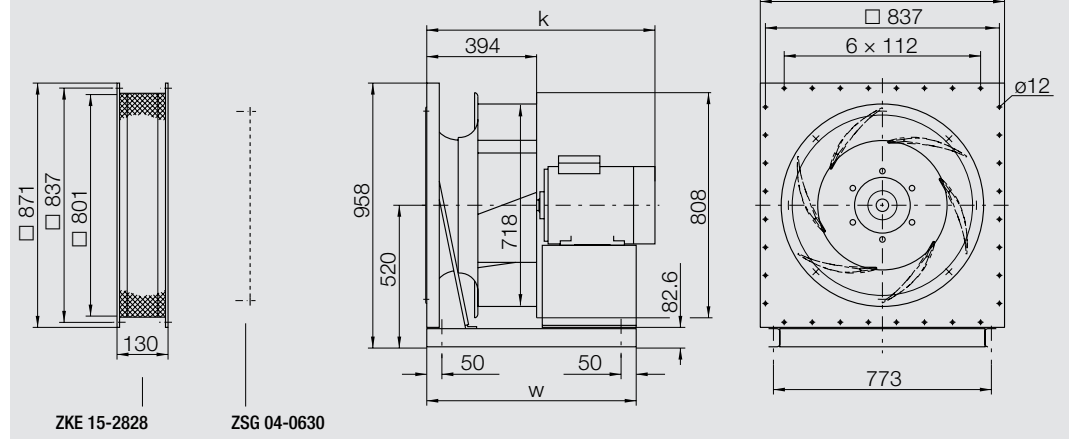

RLM E6-7180

Performance charts

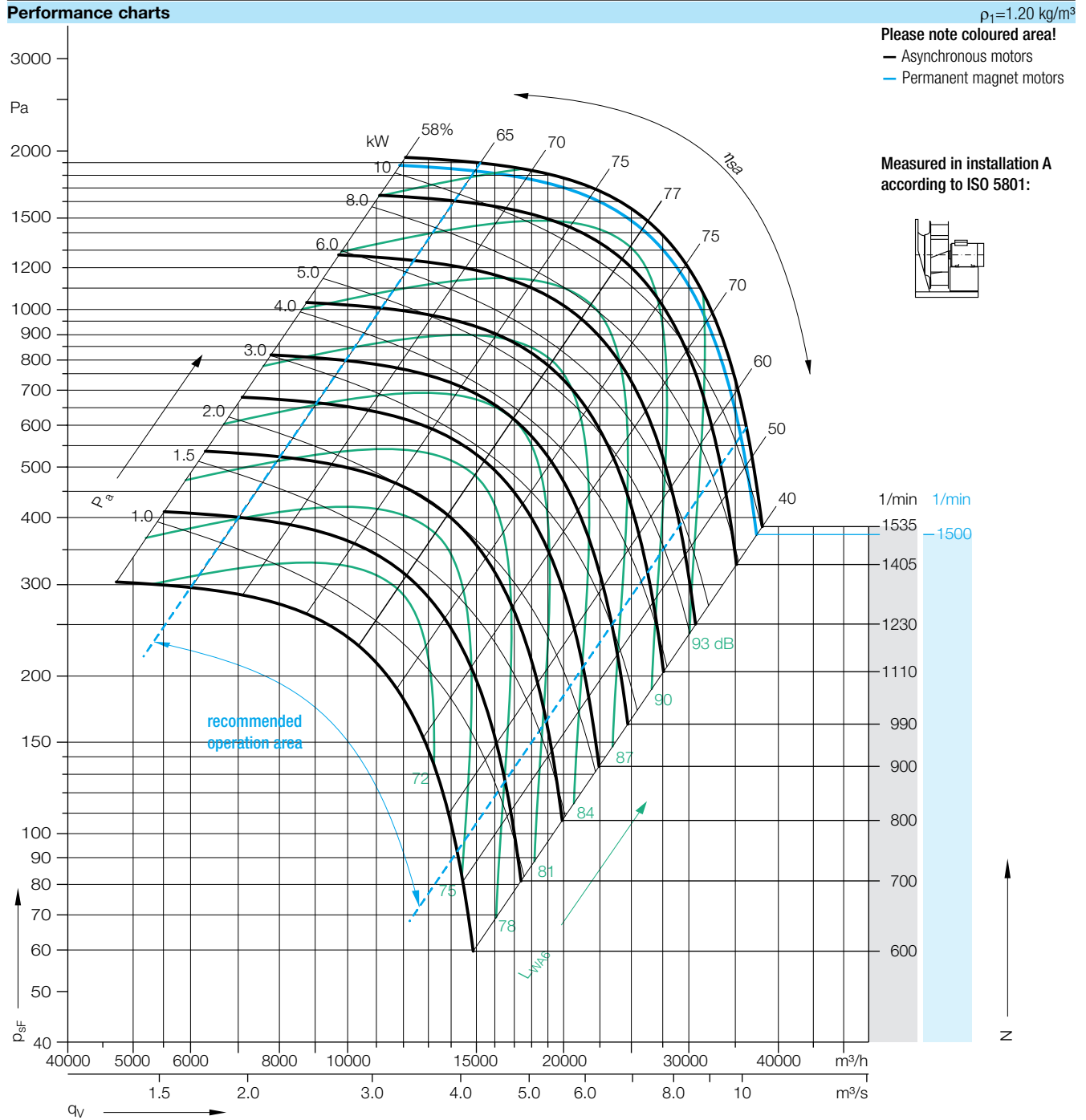

System efficiencies

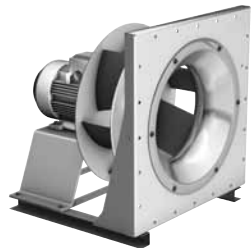

Comparison system efficiencies η_{se} (impeller, motor, inverter)

Model	Speed	Motor Type	65	70	75	77	75	70	60	%
RLM E6-7180-		η_{sa}	65	70	75	77	75	70	60	%
4W-28	1535 1/min	η_{se}	58	62	66	68	66	62	53	%
BE-WU	1500 1/min	η_{se}	59	63	67	69	67	63	54	%

Formula symbols

- η_{se} = overall static efficiency (impeller, motor, inverter)
- η_{sa} = fan shaft static efficiency
- L_{WA6} = A-weighted sound power level at discharge
- P_a = fan shaft power

RLM E6-7180

EVOLUTION
IS IN THE AIR
RLM^{EVO}

Technical Data

Fan type RLM Evo	Motor power kW (max.)	Mains voltage V	Mains frequency Hz	Nominal speed 1/min	Nominal moment Nm	Nominal current A	max. operating frequency Hz	max. speed 1/min	Motor size **	Poles	approx. weight ~kg
RLM E6-7180-4W-28	15.0	400 Δ	50	1475	–	28.0	52	1535	160 L	4	245
RLM E6-7180-6W-28	11.0	400 Δ	50	975	–	22.5	72	1405	160 L	6	222
RLM E6-7180-6W-26	7.5	400 Δ	50	975	–	16.1	63	1230	160 M	6	203
RLM E6-7180-6W-24	5.5	400 Δ	50	970	–	12.0	57	1110	132 M	6	176
RLM E6-7180-6W-23	4.0	400 Δ	50	970	–	8.7	51	990	132 M	6	165
RLM E6-7180-BE-WU-L	15.0	*	*	1500	95.5	31.8	–	1500	132 XXL	–	185

* Motor for operation with inverter only (No mains operation).
We recommend: Danfoss VLT HVAC Drive FC-100.

Fan type code

- W = Asynchronous motor according to efficiency class IE2 (High Efficiency)
- BE = Brushless DC motor with external control unit (efficiency class IE3 and higher)

Dimensions in mm, subject to change.



RLM E6-7180

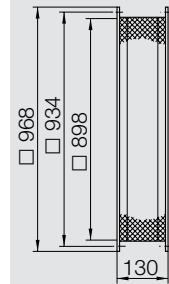

ZKE 15-3030

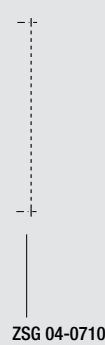

ZSG 04-0710

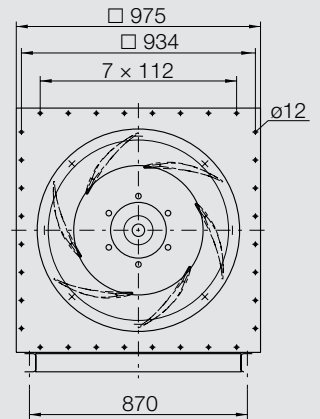
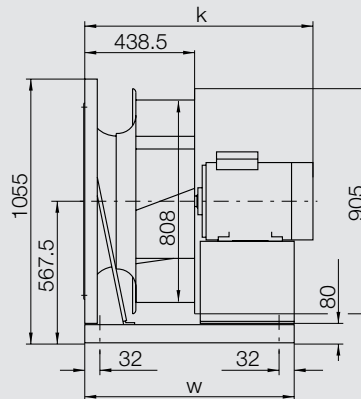

Motor **	k _{max}	w
132 M	859.5	752
132 XXL	926	752
160 M	926	836
160 L	966	836

RLM E6-8090

Performance charts

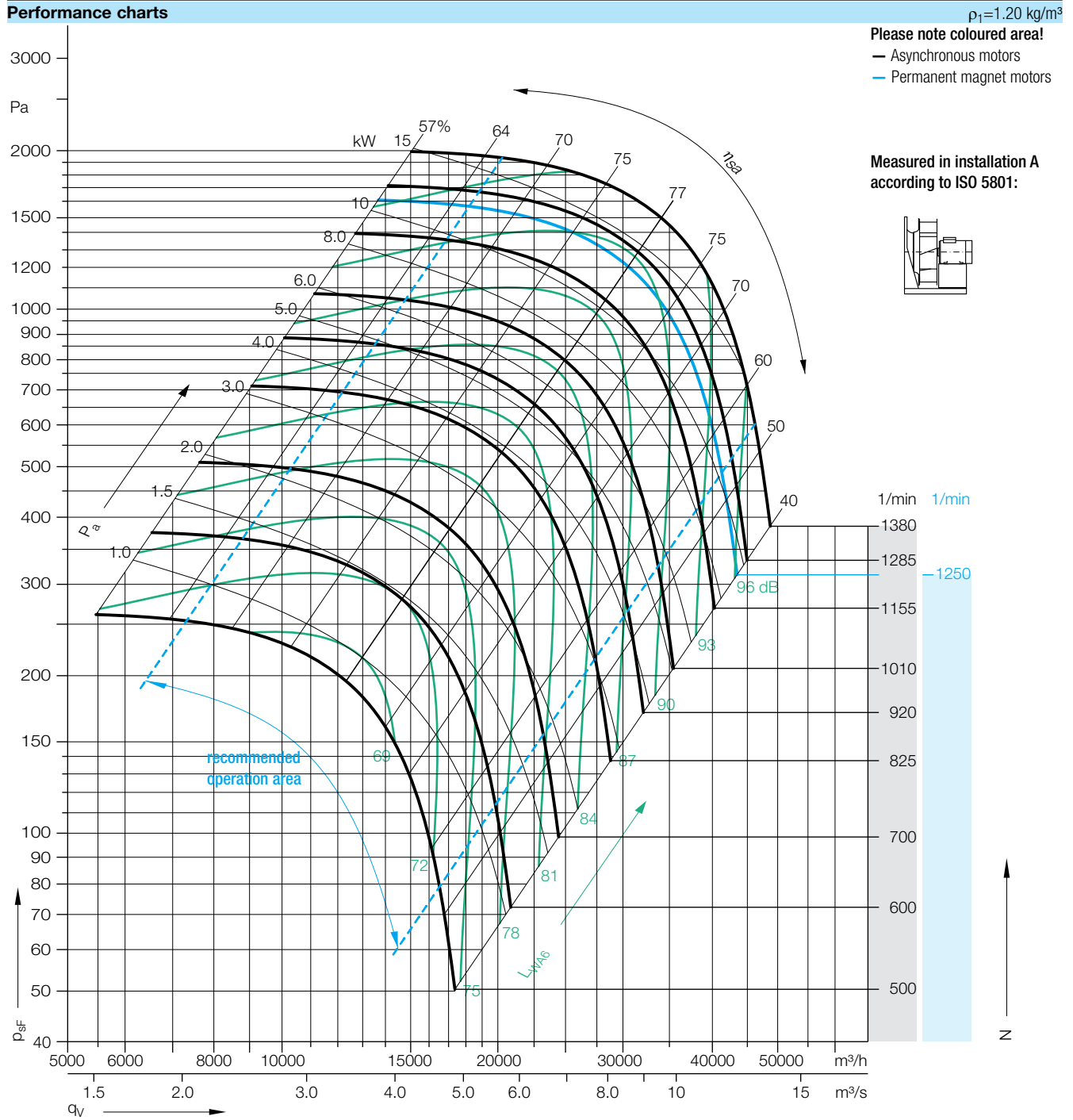

System efficiencies

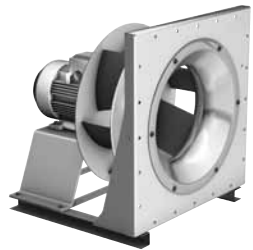

Comparison system efficiencies η_{se} (impeller, motor, inverter)

Model	Speed	Efficiency	64	70	75	77	75	70	60	Unit
RLM E6-8090-		η_{sa}	64	70	75	77	75	70	60	%
6W-33	1380 1/min	η_{se}	57	62	66	68	66	62	53	%
BE-WW	1250 1/min	η_{se}	57	62	67	69	67	62	53	%

Formula symbols

- η_{se} = overall static efficiency (impeller, motor, inverter)
- η_{sa} = fan shaft static efficiency
- L_{WA6} = A-weighted sound power level at discharge
- P_a = fan shaft power

RLM E6-8090

EVOLUTION
IS IN THE AIR
RLM^{EVO}

Technical Data

Fan type RLM Evo	Motor power kW (max.)	Mains voltage V	Mains frequency Hz	Nominal speed 1/min	Nominal moment Nm	Nominal current A	max. operating frequency Hz	max. speed 1/min	Motor size **	Poles	approx. weight ~kg
RLM E6-8090-6W-33	18.5	400 Δ	50	978	–	36.5	70	1380	200 L	6	349
RLM E6-8090-6W-31	15.0	400 Δ	50	975	–	30.0	65	1285	180 L	6	306
RLM E6-8090-6W-28	11.0	400 Δ	50	975	–	22.5	59	1155	160 L	6	249
RLM E6-8090-6W-26	7.5	400 Δ	50	975	–	16.1	51	1010	160 M	6	230
RLM E6-8090-8W-27	5.5	400 Δ	50	730	–	13.3	63	920	160 M	8	235
RLM E6-8090-8W-26	4.0	400 Δ	50	730	–	9.7	56	825	160 M	8	223
RLM E6-8090-BE-WW-L	18.5	*	*	1500	105	39.3	–	1250	132 XXL	–	220

* Motor for operation with inverter only (No mains operation).
We recommend: Danfoss VLT HVAC Drive FC-100.

Fan type code

- W** = Asynchronous motor according to efficiency class IE2 (High Efficiency)
- BE** = Brushless DC motor with external control unit (efficiency class IE3 and higher)

Dimensions in mm, subject to change.



RLM E6-8090

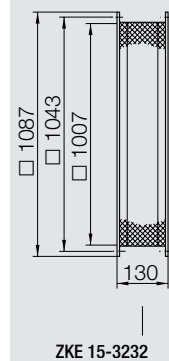

ZSG 04-0800

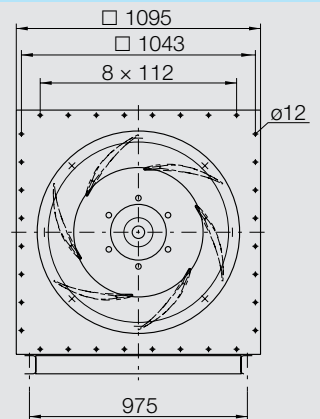
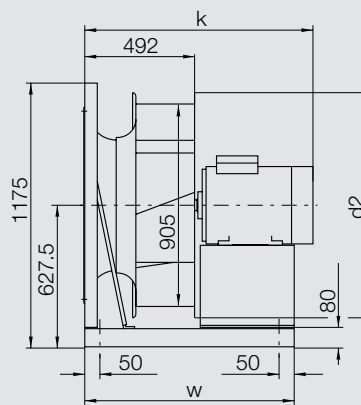

Motor **	k _{max}	w
132 XXL	980	806
160 M	996	890
160 L	1020	890
180 L	1113	943.5
200 L	1112	1012.5

RLM E6-9010

Performance charts

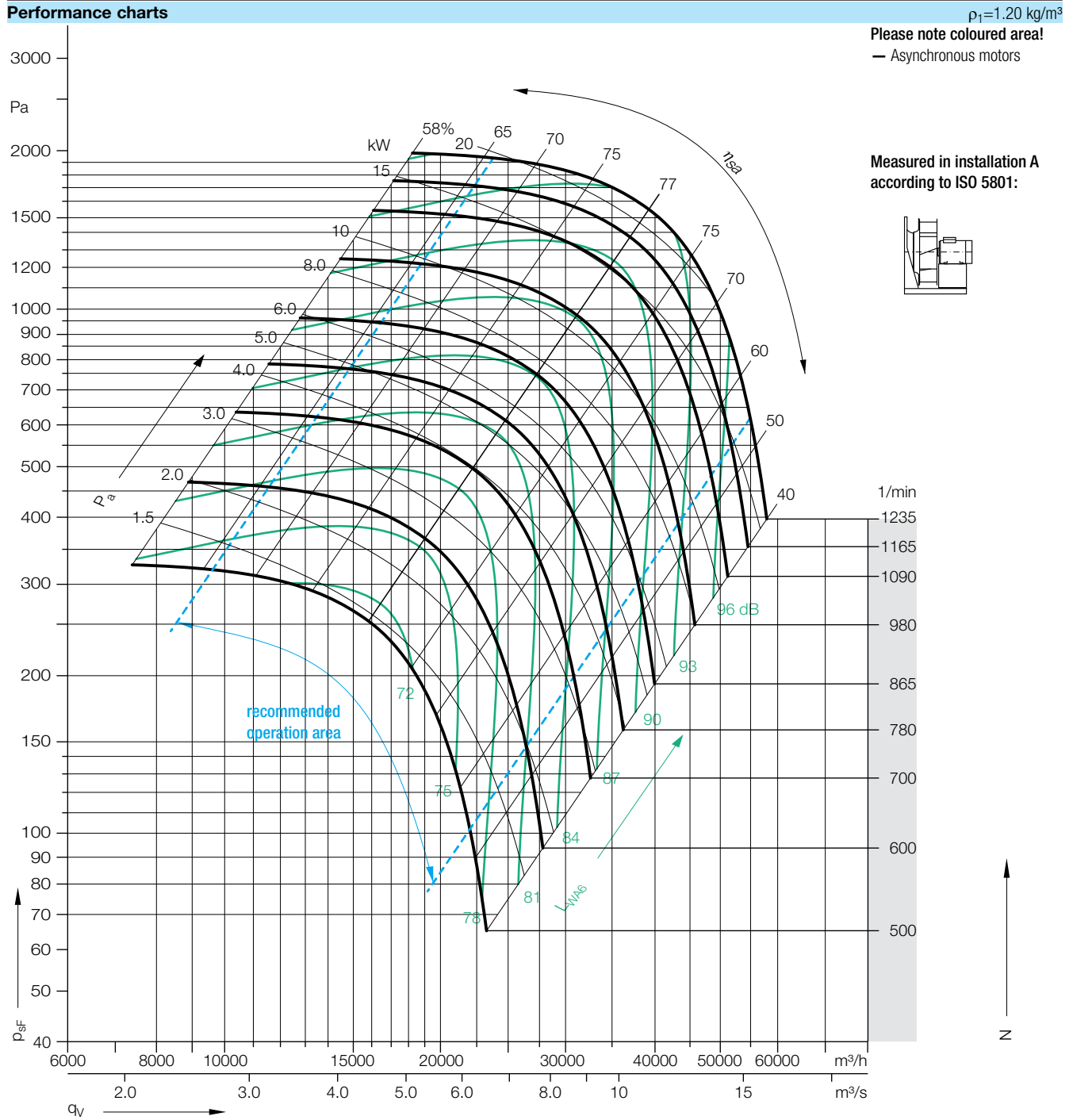

System efficiencies

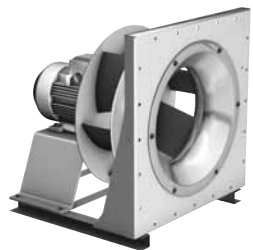

Comparison system efficiencies η_{se} (impeller, motor, inverter)

Model	Speed	Efficiency	65	70	75	77	75	70	60	Unit
RLM E6-9010-		η_{sa}								%
6W-34	1235 1/min	η_{se}	58	62	66	68	66	62	53	%

Formula symbols

- η_{se} = overall static efficiency (impeller, motor, inverter)
- η_{sa} = fan shaft static efficiency
- L_{WA6} = A-weighted sound power level at discharge
- P_a = fan shaft power

RLM E6-9010

EVOLUTION
IS IN THE AIR
RLM^{EVO}

Technical Data

Fan type RLM Evo	Motor power kW (max.)	Mains voltage V	Mains frequency Hz	Nominal speed 1/min	Nominal moment Nm	Nominal current A	max. operating frequency Hz	max. speed 1/min	Motor size **	Poles	approx. weight ~kg
RLM E6-9010-6W-34	22.0	400 Δ	50	978	–	42.5	63	1235	200 L	6	419
RLM E6-9010-6W-33	18.5	400 Δ	50	978	–	36.0	59	1165	200 L	6	388
RLM E6-9010-6W-31	15.0	400 Δ	50	975	–	31.0	55	1090	180 L	6	348
RLM E6-9010-6W-28	11.0	400 Δ	50	975	–	22.5	50	980	160 L	6	296
RLM E6-9010-8W-28	7.5	400 Δ	50	730	–	17.3	59	865	160 L	8	295
RLM E6-9010-8W-27	5.5	400 Δ	50	730	–	13.3	53	780	160 M	8	282

Fan type code

W = Asynchronous motor according to efficiency class IE2 (High Efficiency)

Dimensions in mm, subject to change.



Motor **	k _{max}	w
160 M	1054	952
160 L	1054	952
180 L	1118	990
200 L	1170	1028

RLM E6-9010

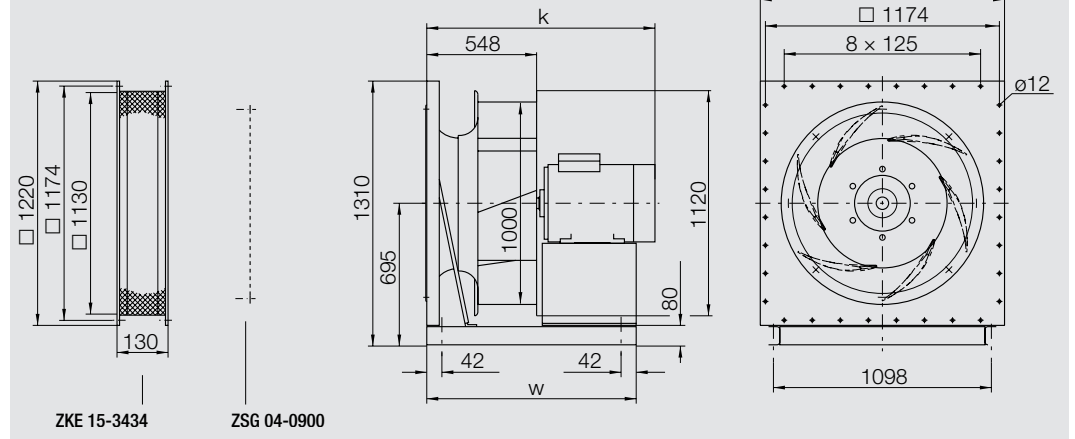

Technical Data according to ErP-REGULATION 327/2011/EU

RLM E6-	Overall efficiency η_e [%]	Measure- ment category	Efficiency category	achieved effi- cency grade at	required efficiency grade acc. to		Speed control (VSD)	Rated motor po- wer at optimum energy efficiency	Flow rate at op- timum energy efficiency	Pressure at op- timum energy efficiency	Speed at op- timum energy efficiency	"specific ratio"
				efficiency	2013	2015						
				"N"				P_e [kW]	q_v [m ³ /h]	p_e [Pa]	N [1/min]	
2528-2D-08	53.6	A	STATIC	65.4	58	62	must be installed	0.75	2180	665	2880	1.007
2528-2W-10	58.5	A	STATIC	69.3	58	62	must be installed	0.93	2407	810	3180	1.008
2528-2W-11	60.1	A	STATIC	69.2	58	62	must be installed	1.35	2755	1062	3640	1.011
2528-2W-13	61.4	A	STATIC	69.2	58	62	must be installed	1.81	3057	1308	4040	1.013
2528-2W-14	62.8	A	STATIC	69.6	58	62	must be installed	2.28	3330	1552	4400	1.016
2831-2W-11	60.1	A	STATIC	69.3	58	62	must be installed	1.33	3192	901	2990	1.009
2831-2W-13	61.4	A	STATIC	69.3	58	62	must be installed	1.77	3534	1104	3310	1.011
2831-2W-14	62.8	A	STATIC	69.1	58	62	must be installed	2.55	4025	1433	3770	1.014
3135-2W-14	62.8	A	STATIC	69.1	58	62	must be installed	2.52	4683	1216	3090	1.012
3135-2W-16	63.9	A	STATIC	68.8	58	62	must be installed	3.41	5213	1507	3440	1.015
3540-2W-19	64.8	A	STATIC	68.8	58	62	must be installed	4.19	6509	1501	3070	1.015
2831-4D-10	50.6	A	STATIC	62.4	58	62	must be installed	0.75	2488	547	2330	1.005
2831-4W-11	60.1	A	STATIC	71.0	58	62	must be installed	0.93	2829	708	2650	1.007
3135-4W-11	60.1	A	STATIC	71.0	58	62	must be installed	0.92	3304	605	2180	1.006
3135-4W-13	61.5	A	STATIC	70.7	58	62	must be installed	1.33	3758	783	2480	1.008
3135-4W-14	62.5	A	STATIC	70.4	58	62	must be installed	1.78	4167	963	2750	1.010
3540-4W-11	60.1	A	STATIC	71.0	58	62	must be installed	0.91	3816	516	1800	1.005
3540-4W-13	61.5	A	STATIC	70.7	58	62	must be installed	1.31	4346	669	2050	1.007
3540-4W-14	62.5	A	STATIC	70.4	58	62	must be installed	1.78	4834	828	2280	1.008
3540-4W-16	63.7	A	STATIC	70.0	58	62	must be installed	2.47	5428	1044	2560	1.010
3540-4W-17	64.6	A	STATIC	69.5	58	62	must be installed	3.36	6043	1294	2850	1.013
4045-4W-13	62.5	A	STATIC	71.8	58	62	must be installed	1.30	5103	575	1710	1.006
4045-4W-14	63.6	A	STATIC	71.5	58	62	must be installed	1.76	5670	710	1900	1.007
4045-4W-16	64.7	A	STATIC	71.1	58	62	must be installed	2.47	6386	900	2140	1.009
4045-4W-17	65.7	A	STATIC	70.5	58	62	must be installed	3.43	7162	1132	2400	1.011
4045-4W-19	66.5	A	STATIC	70.1	58	62	must be installed	4.51	7878	1370	2640	1.014
4045-4W-21	67.4	A	STATIC	70.4	58	62	must be installed	5.09	8237	1498	2760	1.015
4550-4W-14	63.6	A	STATIC	71.6	58	62	must be installed	1.72	6556	601	1560	1.006
4550-4W-16	64.7	A	STATIC	71.2	58	62	must be installed	2.43	7397	765	1760	1.008
4550-4W-17	65.7	A	STATIC	70.6	58	62	must be installed	3.41	8321	968	1980	1.010
4550-4W-19	66.5	A	STATIC	70.2	58	62	must be installed	4.49	9162	1174	2180	1.012
4550-4W-21	67.4	A	STATIC	69.6	58	62	must be installed	6.14	10212	1458	2430	1.015
5056-4W-16	64.7	A	STATIC	71.3	58	62	must be installed	2.39	8537	653	1455	1.007
5056-4W-17	65.7	A	STATIC	70.6	58	62	must be installed	3.38	9622	830	1640	1.008
5056-4W-19	66.5	A	STATIC	70.3	58	62	must be installed	4.41	10561	1000	1800	1.010
5056-4W-21	67.4	A	STATIC	69.6	58	62	must be installed	6.06	11793	1246	2010	1.012
5056-4W-23	68.1	A	STATIC	69.2	58	62	must be installed	7.86	12908	1493	2200	1.015
5663-4W-19	66.5	A	STATIC	70.3	58	62	must be installed	4.37	12292	852	1480	1.009
5663-4W-21	67.4	A	STATIC	69.7	58	62	must be installed	5.98	13703	1059	1650	1.011
5663-4W-23	68.1	A	STATIC	69.1	58	62	must be installed	8.07	15198	1303	1830	1.013
5663-4W-26	69.0	A	STATIC	69.1	58	62	must be installed	9.80	16278	1494	1960	1.015
6371-4W-23	68.1	A	STATIC	69.2	58	62	must be installed	7.90	17590	1101	1500	1.011
6371-4W-26	69.0	A	STATIC	68.9	58	62	must be installed	11.56	20053	1431	1710	1.014
5056-6W-16	61.3	A	STATIC	69.1	58	62	must be installed	1.80	7627	521	1300	1.005
5663-6W-19	62.8	A	STATIC	69.0	58	62	must be installed	2.59	10132	579	1220	1.006
5663-6W-21	64.0	A	STATIC	68.7	58	62	must be installed	3.53	11295	719	1360	1.007
6371-6W-21	64.0	A	STATIC	68.8	58	62	must be installed	3.50	13134	614	1120	1.006
6371-6W-23	65.0	A	STATIC	68.6	58	62	must be installed	4.57	14424	741	1230	1.007
6371-6W-24	66.1	A	STATIC	68.2	58	62	must be installed	6.21	16066	919	1370	1.009
8090-6W-26	67.4	A	STATIC	68.3	58	62	must be installed	8.10	24826	791	1010	1.008
8090-6W-28	68.5	A	STATIC	68.4	58	62	must be installed	11.91	28390	1035	1155	1.010
8090-6W-31	69.3	A	STATIC	68.8	58	62	must be installed	16.21	31586	1281	1285	1.013
8090-6W-33	69.8	A	STATIC	69.1	58	62	must be installed	19.93	33921	1477	1380	1.015
9010-6W-28	68.9	A	STATIC	68.7	58	62	must be installed	12.20	31338	966	980	1.010
9010-6W-31	70.0	A	STATIC	69.5	58	62	must be installed	16.50	34855	1195	1090	1.012
9010-6W-33	70.7	A	STATIC	70.0	58	62	must be installed	20.00	37254	1365	1165	1.014
9010-6W-34	70.9	A	STATIC	70.0	58	62	must be installed	23.80	39492	1534	1235	1.015
8090-8W-26	66.6	A	STATIC	70.3	58	62	must be installed	4.47	20279	528	825	1.005
8090-8W-27	67.0	A	STATIC	69.2	58	62	must be installed	6.16	22614	656	920	1.007
9010-8W-27	67.1	A	STATIC	69.2	58	62	must be installed	6.32	24942	612	780	1.006
9010-8W-28	67.7	A	STATIC	68.5	58	62	must be installed	8.54	27661	753	865	1.008

Technical Data according to ErP-REGULATION 327/2011/EU

RLM E6-	Overall efficiency η_e [%]	Measure-ment category	Efficiency category	achieved efficiency grade at optimum energy efficiency "N"	required efficiency grade acc. to ErP since		Speed control (VSD)	Rated motor power at optimum energy efficiency P_e [kW]	Flow rate at optimum energy efficiency q_v [m ³ /h]	Pressure at optimum energy efficiency p_F [Pa]	Speed at optimum energy efficiency N [1/min]	"specific ratio"
					2013	2015						
2528-BE-AY-L	76.7	A	STATIC	76.7	58	62	must be installed	1.48	2959	1225	3910	1.012
2831-BE-GR-L	76.7	A	STATIC	76.7	58	62	must be installed	2.01	3843	1306	3600	1.013
2831-BE-AY-L	76.8	A	STATIC	76.8	58	62	must be installed	1.15	3149	877	2950	1.009
3135-BE-HN-L	76.1	A	STATIC	76.1	58	62	must be installed	3.06	5198	1498	3430	1.015
3135-BE-GR-L	77.6	A	STATIC	77.6	58	62	must be installed	1.96	4470	1108	2950	1.011
3540-BE-H3-L	76.0	A	STATIC	76.0	58	62	must be installed	3.14	6085	1312	2870	1.013
3540-BE-H5-L	74.6	A	STATIC	74.6	58	62	must be installed	3.86	6509	1501	3070	1.015
4045-BE-H5-L	76.5	A	STATIC	76.5	58	62	must be installed	3.47	7401	1209	2480	1.012
4045-BE-H3-L	79.1	A	STATIC	79.1	58	62	must be installed	2.27	6446	917	2160	1.009
4045-BE-H7-L	74.3	A	STATIC	74.3	58	62	must be installed	4.83	8237	1498	2760	1.015
4550-BE-H7-L	75.1	A	STATIC	75.1	58	62	must be installed	4.26	9204	1185	2190	1.012
4550-BE-H3-L	79.7	A	STATIC	79.7	58	62	must be installed	1.71	6808	648	1620	1.006
4550-BE-H5-L	77.8	A	STATIC	77.8	58	62	must be installed	2.63	7859	864	1870	1.009
5056-BE-VN-L	73.0	A	STATIC	73.0	58	62	must be installed	6.13	12028	1297	2050	1.013
5663-BE-VP-L	72.3	A	STATIC	72.3	58	62	must be installed	7.38	14949	1260	1800	1.013
5663-BE-VN-L	72.4	A	STATIC	72.4	58	62	must be installed	5.29	13288	996	1600	1.010
5663-BE-VR-L	71.4	A	STATIC	71.4	58	62	must be installed	9.50	16278	1494	1960	1.015
6371-BE-VR-L	70.8	A	STATIC	70.8	58	62	must be installed	11.06	19935	1415	1700	1.014
6371-BE-VP-L	72.4	A	STATIC	72.4	58	62	must be installed	5.28	15479	853	1320	1.009
7180-BE-WU-L	70.8	A	STATIC	70.8	58	62	must be installed	14.33	25654	1429	1500	1.014
8090-BE-WW-L	70.9	A	STATIC	70.9	58	62	must be installed	14.52	30725	1212	1250	1.012
2528-BI-BW-L	73.0	A	STATIC	73.0	58	62	integrated	2.17	3330	1552	4400	1.016
2831-BI-HL-L	76.7	A	STATIC	76.7	58	62	integrated	2.01	3843	1306	3600	1.013
3135-BI-HN-L	76.1	A	STATIC	76.1	58	62	integrated	3.06	5198	1498	3430	1.015
3540-BI-H3-L	76.0	A	STATIC	76.0	58	62	integrated	3.14	6085	1312	2870	1.013
4045-BI-H5-L	76.5	A	STATIC	76.5	58	62	integrated	3.47	7401	1209	2480	1.012
4550-BI-H7-L	75.1	A	STATIC	75.1	58	62	integrated	4.26	9204	1185	2190	1.012
5056-BI-UR-L	74.4	A	STATIC	74.4	58	62	integrated	4.17	10561	1000	1800	1.010
5663-BI-VP-L	72.3	A	STATIC	72.3	58	62	integrated	7.38	14949	1260	1800	1.013
6371-BI-VR-L	70.8	A	STATIC	70.8	58	62	integrated	11.06	19935	1415	1700	1.014
2528-BE-IG-M	79.1	A	STATIC	79.1	58	62	integrated	1.53	3027	1282	4000	1.013
2831-BE-IR-M	77.5	A	STATIC	77.5	58	62	integrated	1.99	3843	1306	3600	1.013
3135-BE-QG-M	77.7	A	STATIC	77.7	58	62	integrated	2.36	4773	1263	3150	1.013
3540-BE-WT-M	76.1	A	STATIC	76.1	58	62	integrated	3.22	6149	1340	2900	1.013
4045-BE-WT-M	78.5	A	STATIC	78.5	58	62	integrated	2.90	7013	1086	2350	1.011
4550-BE-YG-M	75.9	A	STATIC	75.9	58	62	integrated	4.27	9246	1195	2200	1.012
5056-BE-YN-M	74.3	A	STATIC	74.3	58	62	integrated	6.02	12028	1297	2050	1.013
5663-BE-YN-M	73.0	A	STATIC	73.0	58	62	integrated	7.54	15115	1288	1820	1.013

Specification

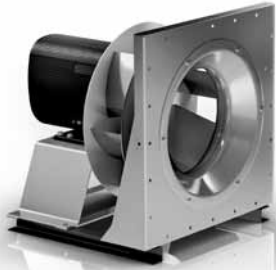
EVOLUTION
IS IN THE AIR
RLM^{EVO}**Plug fan with direct drive RLM Evo**

Complete assembly module with highest system efficiency, specifically developed and optimized for use without a spiral casing and designed for use with a horizontal axis. Newly developed high performance impeller with optimized shape and highest efficiency, comprising six backward curved hollow section true aerofoil blades with real turbulence profile and rounded, inclined blade leading edges, from impeller shroud to backplate, for optimal impact over the entire width of the blade. Co-rotating radial diffuser with optimized exit curving on the cover disc to enhance efficiency.

Impeller made of high tensile sheet steel in an automated manufacturing process, robotic welding, degreased, iron phosphated and coated with a high quality epoxy-polyester mixed powder, fastened with a clamping bush to the shaft of the motor, balanced statically and dynamically according to ISO 1940, specification G2.5, based on the maximum speed from size 4550.

System inlet cone made of galvanized sheet steel for optimal inflow to the impeller, equipped with flow measuring device IMV as a standard feature.

Attached internal rotor motor (mounting arrangement type IM B3) with efficient asynchronous technology (IE2) with 3 PTCs suitable for operation on the frequency inverter **or** with highly efficient permanent magnet technology (IE3 and higher) – optimally coordinated with the high performance impeller.

Equipped on inlet side with connection possibility for quadratic supports.

Complete module optimally adjusted, built to a common base frame prepared for vibration decoupling.

Impeller-Performance data to tolerance class 1 according to DIN 24166.

Variants (at choice)

- ▶ with standard internal rotor motor with asynchronous technology (IE2)
- ▶ with internal rotor motor with permanent magnet technology (IE3 and higher)
 - with integrated control unit (series: BI)
 - with external control unit (series: BE)

Fan Data

Fan type	RLM E6-	
Volume flow	Q_V	m ³ /h
Fan static pressure	p_{sF}	Pa
Air density at inlet	ρ_1	kg/m ³
Media temperature	t	°C
Fan power	P_a	kW
Efficiency	η_{sa}	Hz
speed	N	1/min
Max. fan speed	N_{max}	1/min
Frequency	f	Hz
Max. operating frequency	f_{max}	Hz
Sound power level (A weighted)	L_{WA}	dB
Weight	m	kg

Fittings / Accessories

- ▶ Mating flange
- ▶ Inlet connection (flexible)
- ▶ Protection guard for inlet
- ▶ Anti vibration mounts (spring diffusors)
- ▶ Inverter for AC motors (Unit with Filter and Control Panel)
- ▶ Inverter for brushless DC motors (Unit with Filter, Line Choke and Control Panel)
- ▶ Line choke
- ▶ Universal control device
- ▶ Differential pressure sensor

Description

$$\eta_{se} = \eta_F \cdot \eta_M \cdot \eta_{sa}$$

$$P_e = \frac{q_v \cdot p_{sF}}{\eta_{se}}$$

The system efficiency is the product of the efficiencies of the frequency inverter, motor and impeller.
The electric power of the fan taken from the mains can be determined with the system efficiency.

Performance data



The performance curves of the fans are determined at the plenum test rig according to ISO 5801, measured in installation „A“.

The curves show a free discharge pressure rise p_{sF} as a function of the volume flow rate q_v in double logarithmic grid distribution. The resistant curves appear as straight lines.

The fan curves are related to a reference density of $\rho_1 = 1.2 \text{ kg/m}^3$ at the fan intake. The pressure and impeller power are directly proportional to the density ρ_1 .

The efficiencies η_{sa} given in the performance curves are only valid for the impeller.

The performance data of the RLM centrifugal fans are classified in precision class 1 according to DIN 24166 "Fans, technical delivery conditions".

Sounds

$$L_{WA5} = L_{WA6} - \Delta L_{WA}$$

q_{Vopt}	≤ 0.85	> 0.85
ΔL_{WA}	4 dB	5 dB

Sound measurement and analysis are carried out in accordance with DIN 45635-38 "Sound measurement at machines; fans".

In the performance maps the A sound power level L_{WA6} is stated as emission parameter for the discharge side.

The value for the inlet side L_{WA5} can be calculated with the stated formula.

Inlet side

$$L_{Wfc5} = L_{WA5} + L_{Wrel5}$$

Relative sound power level for inlet side L_{Wrel5} at octave centre frequencies f_c .

RLM E6-	Duty Point	63	125	250	500	1000	2000	4000	8000	Hz
2528/-2831	0.50...0.85 q_{Vopt}	-11	-10	+2	-3	-6	-11	-12	-21	dB
	$>0.85...1.30 q_{Vopt}$	-10	-10	-1	-4	-5	-9	-9	-15	dB
	$>1.30 q_{Vopt}$	-9	-13	-1	-5	-7	-10	-6	-11	dB
3135/-3540	0.50...0.85 q_{Vopt}	-11	-10	+4	-2	-9	-10	-13	-20	dB
	$>0.85...1.30 q_{Vopt}$	-8	-9	+2	-2	-8	-10	-11	-18	dB
	$>1.30 q_{Vopt}$	-10	-11	+1	-3	-8	-10	-8	-14	dB
4045/-4550	0.50...0.85 q_{Vopt}	-7	+4	0	-3	-8	-8	-9	-16	dB
	$>0.85...1.30 q_{Vopt}$	-8	-2	0	-6	-8	-7	-8	-13	dB
	$>1.30 q_{Vopt}$	-11	-5	-4	-8	-9	-6	-7	-10	dB
5056/-6371	0.50...0.85 q_{Vopt}	-4	+6	+1	-3	-6	-9	-11	-17	dB
	$>0.85...1.30 q_{Vopt}$	-4	+2	-1	-4	-6	-8	-10	-13	dB
	$>1.30 q_{Vopt}$	-6	+2	-2	-6	-9	-7	-8	-9	dB

Discharge

$$L_{Wfc6} = L_{WA6} + L_{Wrel6}$$

Relative sound power level for discharge side L_{Wrel6} at octave centre frequencies f_c .

RLM E6-	Duty Point	63	125	250	500	1000	2000	4000	8000	Hz
2528/-2831	0.50...0.85 q_{Vopt}	-7	-10	-2	-6	-5	-6	-10	-18	dB
	$>0.85...1.30 q_{Vopt}$	-7	-10	-6	-10	-6	-6	-7	-14	dB
	$>1.30 q_{Vopt}$	-10	-12	-7	-11	-8	-7	-5	-12	dB
3135/-3540	0.50...0.85 q_{Vopt}	-4	-9	+2	-7	-6	-8	-10	-18	dB
	$>0.85...1.30 q_{Vopt}$	-5	-8	-3	-8	-5	-8	-7	-14	dB
	$>1.30 q_{Vopt}$	-8	-12	-4	-9	-7	-8	-5	-12	dB
4045/-4550	0.50...0.85 q_{Vopt}	-10	-3	-5	-8	-5	-5	-10	-18	dB
	$>0.85...1.30 q_{Vopt}$	-13	-8	-8	-10	-7	-5	-8	-15	dB
	$>1.30 q_{Vopt}$	-15	-12	-11	-12	-10	-4	-6	-13	dB
5056/-6371	0.50...0.85 q_{Vopt}	-5	+4	-2	-5	-5	-7	-12	-17	dB
	$>0.85...1.30 q_{Vopt}$	-6	-1	-5	-5	-5	-8	-10	-13	dB
	$>1.30 q_{Vopt}$	-10	-3	-7	-7	-8	-6	-6	-11	dB

Anti Vibration Mounts

AV mounts are designed to prevent noise and vibrations being transmitted through the base of the fan.

AV mounts should be mounted beneath the fan base frame so the weight and spring deflections are evenly distributed. They should not be mounted symmetrically because a counter force is induced into the system by the pressure created by the working fan.

It is difficult for the manufacturer to establish the position of the AV mounts to suit all types of application.

Vibration and noise insulation can also be improved by ensuring that the fan is connected to its external environment by a flexible coupling.

Available AV mounts for different fans, see proSELECTA II.

The AVM-mounts are supplied with the suitable mounting material for the base frame.

Rubber Buffers

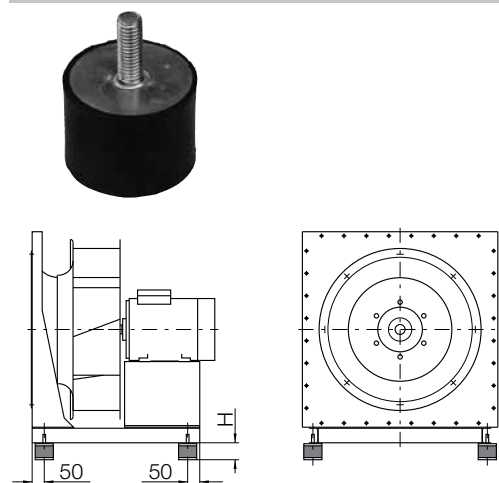

Rubber buffers for noise insulation only.

Quantity „z“ Rubber Buffers ZBD. Inlet-side ① / Motor-Side ②.

RLM Evo	H max. [mm]	z × ZBD ①	z × ZBD ②
RLM E6-2528	30	2 × *	2 × *
RLM E6-2831	30	2 × *	2 × *
RLM E6-3135	30	2 × *	2 × *
RLM E6-3540	30	2 × *	2 × *
RLM E6-4045	30	2 × *	2 × *
RLM E6-4550	30	2 × *	2 × *
RLM E6-5056	30	2 × *	2 × *
RLM E6-5663	30	2 × *	2 × *
RLM E6-6371	50	2 × *	2 × *
RLM E6-8090	50	2 × *	2 × *

* Assignment on request.

Anti Vibration Mounts



ZBD SP-770



ZBD SP-750

Spring diffusers with noise insulation layer and height adjustment, for both vibration and noise insulation.

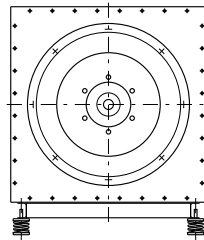
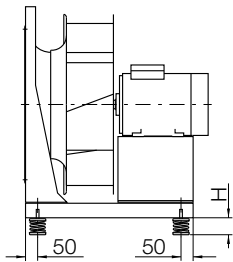
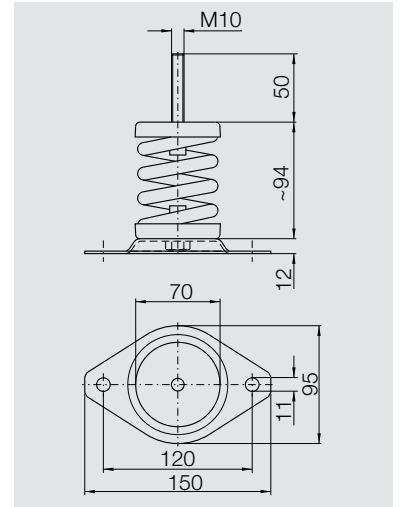
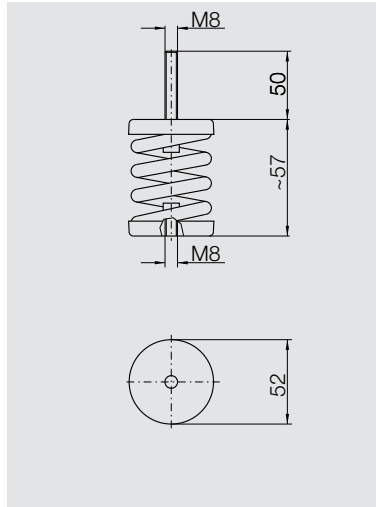

Quantity „z“ anti-vibration-mounts ZBD. Inlet-side ① / Motor-Side ②.

RLM Evo	H max. [mm]	z × ZBD ①	z × ZBD ②
RLM E6-2528- _W/_D	~57	2 × SP-770*	2 × SP-770*
RLM E6-2831- _W/_D	~57	2 × SP-770*	2 × SP-770*
RLM E6-3135- _W	~57	2 × SP-770*	2 × SP-770*
RLM E6-3540- _W	~57	2 × SP-770*	2 × SP-770*
RLM E6-4045- _W	~106	2 × SP-750*	2 × SP-750*
RLM E6-4550- _W	~106	2 × SP-750*	2 × SP-750*
RLM E6-5056- _W	~106	2 × SP-750*	2 × SP-750*
RLM E6-5663- _W	~106	2 × SP-750*	2 × SP-750*
RLM E6-6371- _W	~106	2 × SP-750*	2 × SP-750*
RLM E6-8090- _W	~106	2 × SP-750*	2 × SP-750*

RLM Evo	H max. [mm]	z × ZBD ①	z × ZBD ②
RLM E6-2528-BI/BE-L	~57	2 × SP-770*	2 × SP-770*
RLM E6-2831-BI/BE-L	~57	2 × SP-770*	2 × SP-770*
RLM E6-3135-BI/BE-L	~57	2 × SP-770*	2 × SP-770*
RLM E6-3540-BI/BE-L	~57	2 × SP-770*	2 × SP-770*
RLM E6-4045-BI/BE-L	~106	2 × SP-750*	2 × SP-750*
RLM E6-4550-BI/BE-L	~106	2 × SP-750*	2 × SP-750*
RLM E6-5056-BI/BE-L	~106	2 × SP-750*	2 × SP-750*
RLM E6-5663-BI/BE-L	~106	2 × SP-750*	2 × SP-750*
RLM E6-6371-BI/BE-L	~106	2 × SP-750*	2 × SP-750*

RLM Evo	H max. [mm]	z × ZBD ①	z × ZBD ②
RLM E6-2528-BE-M	~57	2 × SP-770*	2 × SP-770*
RLM E6-2831-BE-M	~57	2 × SP-770*	2 × SP-770*
RLM E6-3135-BE-M	~57	2 × SP-770*	2 × SP-770*
RLM E6-3540-BE-M	~57	2 × SP-770*	2 × SP-770*
RLM E6-4045-BE-M	~57	2 × SP-770*	2 × SP-770*
RLM E6-4550-BE-M	~57	2 × SP-770*	2 × SP-770*
RLM E6-5056-BE-M	~57	2 × SP-770*	2 × SP-770*
RLM E6-5663-BE-M	~57	2 × SP-770*	2 × SP-770*

* Assignment on request.

RLMEVO

Volumeter

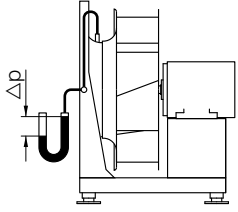

$$q_v = K \times \sqrt{\frac{2}{\rho} \times \Delta p_{Dü}}$$



pressure tapplings in inlet cones

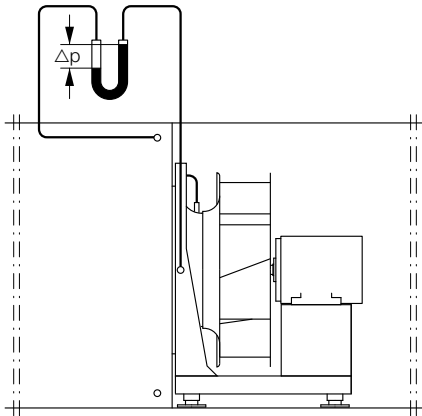

The fans are equipped with a flow measuring device as standard. With the flow measuring device it is possible to measure/monitor the flow easily after the fan is installed.

For pressure measurement A pressure tapping at a predetermined position on the inlet cone is provided whereby the decrease in pressure created by the cone can be measured. The decrease in pressure measured can be inserted in the following formula.

- ▶ q_v Volume flow m^3/h
- ▶ K calibration factor m^2s/h
- ▶ ρ density of media kg/m^3
- ▶ $\Delta p_{Dü}$ pressure difference at cone Pa

The K factor is determined by comparative measurement on a standard test ring.

When fans are built in a plenum, it is required to measure the differential pressure between the static pressure in the plenum on the suction side and the pressure at the inlet cone.

To ensure that the static pressure to be measured at the inlet nozzle is not distorted by dynamic velocities, it is recommended to attach a ring of points on the wall as shown in the following diagram.

If the differential pressure is conducted via a pressure sensor, the signal can also be used for controlling.

Detailed description, measurement and connection diagram available on request.

Calibration factors

RLM	K [m ² s/h]	RLM	K [m ² s/h]
RLM E6-2528	79	RLM E6-5056	242
RLM E6-2831	94	RLM E6-5663	310
RLM E6-3135	106	RLM E6-6371	385
RLM E6-3540	128	RLM E6-7180	490
RLM E6-4045	155	RLM E6-8090	628
RLM E6-4550	190	RLM E6-9010	794

Correction of design for installation in an enclosure

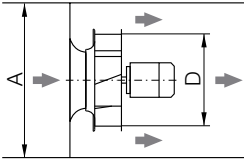

Installing the fan in a casing may result in a reduced flow rate and pressure increase relative to the information in the performance map which is determined freely discharging in accordance with the prescribed standards.

The pressure loss can be calculated as a function of the size of the casing with the loss coefficient ζ for the installed casing from the following diagram. The values in the diagram apply when the box sections are quadratic and the impeller is laid out symmetrically (inflow and outflow according to the diagram).

If casings with rectangular sections are used the following approximate values can be used for box size A:

- ζ Loss coefficient for casing installation
- A Inside casing width or length
- D_2 Throat plate diameter

► Max. side length B_{max} / min. side length $B_{min} \leq 1.3$:

$$A = \sqrt{B_{max} \cdot B_{min}}$$

► Max. side length B_{max} / min. side length $B_{min} > 1.3$:

$$A = 1.14 \cdot B_{min}$$

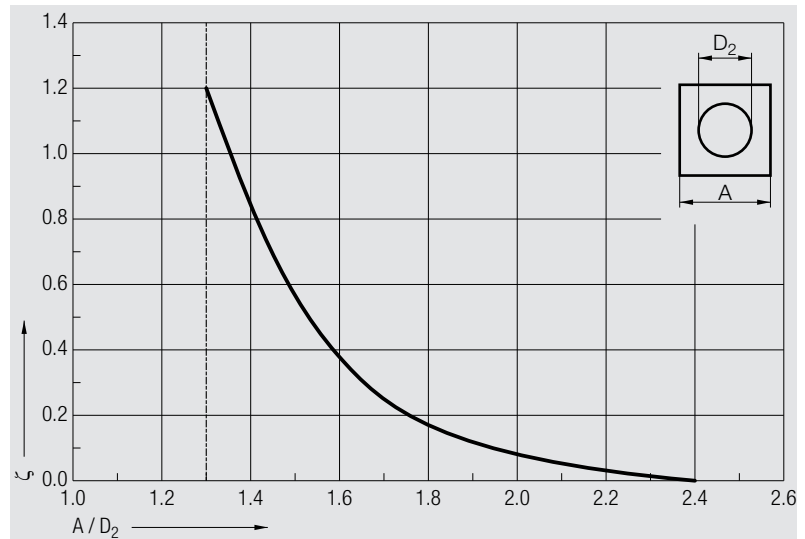

If the impeller is laid out asymmetrically, the loss coefficients are up to 20 % higher. A minimum distance of the impeller to the surrounding wall of $0.15 \cdot D_2$ must be observed.

- p_V Pressure loss in Pa
- ζ Loss coefficient for casing installation
- ρ Reference density of conveyed air (usually: 1.2 kg/m³)
- q_V Flow rate in m³/h
- D_2 Throat plate diameter in mm

The pressure loss is calculated with the loss coefficient determined in accordance with the following formula:

$$p_V = 100200 \cdot \zeta \cdot \rho \frac{q_V^2}{D_2^4}$$

The throat plate diameters for the calculation can be taken from the respective dimension diagram of the fan. The pressure loss is added to the desired pressure increase in the operating point and the fan is selected with the corrected value.

Nicotra Gebhardt worldwide

SPAIN

Ctra. Alcalá-Villar del Olmo, Km. 2,830
28810 Villalbilla-Madrid
Phone +34 918-846110
Fax +34 918-859450
E-mail info@nicotra.es

c/.Coso, 67-75, esc. 1.a,1.oB
50001 Zaragoza
Phone +34 976-290550
Fax +34 976-298127
E-mail gebhardt@teleline.es

BELGIUM

Haeghensgoed, 13 - 00/01
9270 Laarne
Phone +32 (0)9-336-00-01
Fax +32 (0)9-336-00-05
E-mail info.nicotra@nicotra.be

FRANCE

Leader's Park Bat A1
3 chemin des Cytises
69340 Francheville
Phone +33 (0)4 72 79 01 20
Fax +33 (0)4 72 79 01 21
E-mail g.cauche@nicotra-gebhardt.com

SWEDEN

Box 237
Kraketorpsgratan 30
43123 Mölndal
Phone 0046 31-874540
Fax 0046 31-878590
E-mail info.se@nicotra-gebhardt.com

GREAT BRITAIN

Unit D, Rail Mill Way
Parkgate Business Park
Rotherham
South Yorkshire
S62 6JQ
Phone +044 01709-780760
Fax +044 01709-780762
E-mail sales@nicotra.co.uk

UNITED STATES

PO BOX 900921
Sandy, Utah 84090
Phone 001(801) 733-0248
Fax 001(801) 315-9400
Mobile 001(801) 682 0898
E-mail mike.sehgal@gebhardtfans.com
<http://www.gebhardtfans.com/>



MALAYSIA

Lot 1799, Jalan Balakong
Taman Perindustrian Bukit Belimbing
43300 Seri Kembangan
Selangor
Phone +603 8961-2588
Fax +603 8961-8337
E-mail info_malaysia@nicotra-gebhardt.com

THAILAND

6/29 Soi Suksawadi 2, Moo 4, Suksawadi Road,
Kwang Jomthong, Khet Jomthong,
Bangkok 10150
Phone +662 476-1823-6
Fax +662 476-1827
E-mail sales@nicotra.co.th

SINGAPORE

3, Science Park Drive, # 04-07, The Franklin
Singapore Science Park 1
Singapore 118223
Phone +65 6265 1522
Fax +65 6265 2400
E-mail info_singapore@nicotra-gebhardt.com

AUSTRALIA

65 Yale Drive,
Epping, VIC 3076
Phone +61 3 9017 5333
Fax +61 3 8401 3969
E-mail info@nicotra.com.au

INDIA

Plot no 28F & 29, Sector-31, Kasna,
Greater Noida-201 308 U.P (India)
Phone +91 120 4783400
Phone +91 22 65702056 (Mumbai)
Phone +91 80 25727830 (Bangalore)
E-mail info@nicotraindia.com

CHINA

88 Tai'An Road, XinQiao, ShiJi, Panyu
Guangzhou 511450
PR CHINA
Phone +86 (0)20-39960570
Fax +86 (0)20-39960569
E-mail sales@nicotra-china.com

Nicotra Gebhardt Germany

Nicotra Gebhardt GmbH
Gebhardtstraße 19-25
74638 Waldenburg
Germany
Phone +49 (0)7942 101 0
Fax +49 (0)7942 101 170
E-Mail info@nicotra-gebhardt.com

Nicotra Gebhardt Italy

Nicotra Gebhardt S.p.A
Via Modena, 18
24040 Zingonia (BG)
Italy
Phone +39 035 873 111
Fax +39 035 884 319
E-Mail info@nicotra-gebhardt.com

nicotra-gebhardt.com